



# Highlands Recreation District

1851 Lexington Avenue • San Mateo, CA 94402

(650) 341-4251 • Fax (650) 349-9627

[www.highlandsrec.ca.gov](http://www.highlandsrec.ca.gov)

*"A Community Place to Learn, Grow & Play"*

## NOTICE INVITING BIDS

### FOR

## Highlands Recreation District Playground and Sports Court Renovation Project

### Bid Documents Table of Contents

1. Notice inviting BIDS .....	Page 1-2
2. Acknowledgement Form .....	Page 3
3. Instructions for Bidders .....	Page 4-11
4. Department of Industrial Relations and SB 854 Compliance Affidavit .....	Page 12
5. Highlands Recreation District Contract .....	Page 13-18
6. General Conditions .....	Page 19-36
7. Certification by Contractor .....	Page 37
8. California Public Contract Code .....	Page 38-40
9. Bid Form .....	Page 41-44
10. Bid Items Detail .....	Page 45-47
11. Additional Alternate Items Detail .....	Page 48
12. List of Subcontractors .....	Page 49-50
13. Bidder's Responsibility Statement .....	Page 51-54
14. Noncollusion Affidavit .....	Page 55
15. Bid Guarantee .....	Page 56
16. Summary of Work .....	Page 57-58
17. Technical Specifications and Related Documents .....	Page 59
18. Drawings .....	Page 60-78



# Highlands Recreation District

1851 Lexington Avenue • San Mateo, CA 94402

(650) 341-4251 • Fax (650) 349-9627

[www.highlandsrec.ca.gov](http://www.highlandsrec.ca.gov)

*"A Community Place to Learn, Grow & Play"*

## NOTICE INVITING BIDS FOR Highlands Recreation District Playground and Sports Court Renovation Project

NOTICE IS HEREBY GIVEN that the Highlands Recreation District (District) invites sealed Bids for the **HRD Playground and Sports Court Renovation Project**, more specifically defined in the Contract Documents, which generally consists of:

Furnishing Labor and Materials, Demolition and Disposal, Earthwork, Installation of Playground and Sports Court Equipment and Amenities, Engineered Wood Fiber, Asphalt Repair and Sealant, Temporary Fencing and Cleanup at the Highlands Recreation District Grounds.

All general contractors who wish to submit a bid for this project shall attend a **mandatory pre-bid job walk through at the project site at 10:00 am on Thursday, April 21, 2022**, with the General Manager, Derek Schweigart at 1851 Lexington Ave., San Mateo, CA. Bidders must email any questions to Mr. Schweigart at [generalmanager@highlandsrec.ca.gov](mailto:generalmanager@highlandsrec.ca.gov) no later than five working days prior to the bid opening. Responses to all questions will be posted and available on the project page at [www.highlandsrec.ca.gov/hrd-playground](http://www.highlandsrec.ca.gov/hrd-playground) three working days before the bid opening. Bidders must follow all County and State health and safety guidance concerning appropriate social distancing and mask requirements during the site visit.

General contractors wishing to submit a bid for the project should visit project web page at [www.highlandsrec.ca.gov/hrd-playground](http://www.highlandsrec.ca.gov/hrd-playground) to get a copy of the plans, specifications, and contract documents for the project. For more information, you may email the General Manager at [generalmanager@highlandsrec.ca.gov](mailto:generalmanager@highlandsrec.ca.gov).

All bids shall be accompanied by cash or a cashier's check or certified check payable to the order of the Highlands Recreation District, amounting to (10%) percent of the Bid, or by a bidder's bond executed by an admitted surety insurer in said amount and payable to the Highlands Recreation District (hereinafter "Security"). If the Bidder fails, within ten (10) working days after written notice that the Contract has been awarded to him, to enter a Contract with the Highlands Recreation District, the Highlands Recreation District may award the Contract to the second lowest bidder. In such event, the amount of Bidder's Security shall be applied by the Highlands Recreation District to the difference between the Bidder's Bid and the second lowest Bid, and the surplus of the Security, if any, shall be returned to the Bidder if cash or check is used, or to the surety on Bidder's bond if a bond is used.

The Bids must be on forms obtained as set forth above and must be delivered to the Highlands Recreation District at 1851 Lexington Ave., San Mateo, CA 94131 in a sealed envelope marked "**Bid For**

**HRD Playground and Sports Court Renovation Project”, up to but not later than 10:00 am on April 29, 2022.** Bids will be publicly opened, examined, and read aloud at that time and place. The Highlands Recreation Board of Directors reserves the right to reject any and all Bids.

At the successful Contractor's option, securities may be substituted for the required retention, in accordance with the provisions of Section 22300 of the State of California Public Contract Code.

In accordance with the provisions of California Public Contract Code Section 3300, the District has determined that the Contractor shall possess, as a minimum, a valid Class A or B License. In accordance with the provisions of California Business and Professions Code Section 7028.15, a bid submitted to the District by a Contractor who is not licensed in accordance with Chapter 9 of the California Business and Professions Code shall be considered non-responsive and shall be rejected by the District.

No bidder may withdraw its bid for a period of sixty (60) days after the date set for the opening thereof.

**BID PROTEST:** Any Bid protest must be submitted in writing to the General Manager at the District offices located at 1851 Lexington Ave., San Mateo, CA 94131 before 5:00 pm of the fifth Business Day following transmission and posting of the District’s Notice of Intent to Award. The notice will be posted at the District offices. The District will use reasonable efforts to deliver by facsimile and/or e-mail a copy of the Notice of Intent to Award to all Bidders who submitted Bids no later than the Business Day after issuance, although any delay or failure to do so will not extend the Bid protest deadline described above.

Prevailing wage as determined by the State of California, Director of Industrial Relations are required for this project, a copy of which is available at the HRD offices. This is a public works project subject to the registration and reporting requirements of SB 854.

**ACKNOWLEDGEMENT  
FOR  
Highlands Recreation District Playground and Sports Court Renovation Project**

To ensure all bid materials were received, this Acknowledgement must be completed and returned in the bidder's sealed envelope for the Bid prior to **10:00 am on April 29, 2022**. This sheet acknowledges receipt of the following materials:

1. Notice Inviting Bids
2. Acknowledgement
3. Instructions for Bidders
4. Contract
5. General Conditions
6. California Public Contract Code Section 20104
7. Bid Form
8. List of Subcontractors
9. Bidders Responsibility Statement
10. Non-Collusion Affidavit
11. Bid Guarantee
12. Contract Specifications
13. Drawings
14. Addenda(s) receipt(s) through No. \_\_\_\_\_, if applicable

In addition to the above materials, the Bidder acknowledges the following:

1. A Faithful Performance Bond and Payment Bond are required for this project.
2. Liquidated damages in the amount of **\$200** a day will be assessed by the Owner for each day beyond the contract specified number of days that the project is not completed by the Contractor.
3. Names and phone numbers of references for a minimum of two (2) similar projects are to be provided with the bid.

**Bid submittals received without this completed sheet will be deemed incomplete and will not be considered in the award process.**

Acknowledged by: \_\_\_\_\_

Company: \_\_\_\_\_

License No. \_\_\_\_\_

Bidder: \_\_\_\_\_

Title: \_\_\_\_\_

Date: \_\_\_\_\_

**INSTRUCTIONS FOR BIDDERS  
FOR  
Highlands Recreation District Playground and Sports Court Renovation Project**

1. OBTAINING COPIES OF CONTRACT DOCUMENTS

General contractors wishing to submit a bid for the project should visit the project web page at [www.highlandsrec.ca.gov/hrd-playground](http://www.highlandsrec.ca.gov/hrd-playground) to get a copy of the plans, specifications, and contract documents for the project. For more information, you may email the General Manager at [generalmanager@highlandsrec.ca.gov](mailto:generalmanager@highlandsrec.ca.gov).

2. FORM OF BID

All Bids must be made on regular Bid Forms which are made a part of these Contract Documents and must be enclosed in a sealed envelope, marked as required in the "Notice Inviting Bids." The Bid must be signed by the individual or by the proper officials of the firm or corporation by which the Bid is made. The right is reserved to reject any and all Bids and to waive technical defects as the interests of the District require.

3. INTERPRETATION OR CORRECTION OF CONTRACT DOCUMENTS

- a. Bidder shall, before submitting its Bid, carefully study and compare the components of the Contract Documents and shall examine the Project Site, the conditions under which the Work is to be performed, and the local conditions.
- b. In the event Bidder has any question as to the meaning of any part of the Contract Documents, or Bidder finds any error, inconsistency, or ambiguity in the Contract Documents, Bidder shall make a written Request for Clarification prior to submitting its Bid. Requests for Clarification or interpretation of the Contract Documents shall be addressed only to the District General Manager Mr. Derek Schweigart at [generalmanager@highlandsrec.ca.gov](mailto:generalmanager@highlandsrec.ca.gov). It shall be the Bidder's responsibility to ensure that any such request be submitted to the District, in a timely manner no less than five (5) working days prior to the bid opening, in order to allow for the District to issue a written Addenda.
- c. If necessary, the District shall make clarifications, interpretations, corrections, and changes to the Contract Documents by Addenda issued as provided below. Purported clarifications, interpretations, corrections, and changes to the Contract Documents made in any other manner shall not be binding on the Highlands Recreation District and Bidders shall not rely upon them.

4. ADDENDA

- a. The District will make Addenda available online at the following website: [www.highlandsrec.ca.gov/hrd-playground](http://www.highlandsrec.ca.gov/hrd-playground). It is Bidder's responsibility to check the website and review Addenda prior to submitting a Bid.

- b. Addenda withdrawing the Invitation for Bids or postponing the Bid Deadline may be issued any time prior to the Bid Deadline. However, if any Addenda issued later than 72 hours prior to the bid closing results in a material change to the Contract Documents, the Bid Deadline shall be extended by the District by not less than 72 hours, pursuant to Public Contract Code section 4104.5.
- c. Each Bidder shall be responsible for ascertaining, prior to submitting its Bid, that it has received all issued Addenda. Each Bidder shall acknowledge receipt of all Addenda on the Bid Form. Failure to acknowledge receipt of Addenda may render the Bid non-responsive.

5. EXAMINATION OF SITE AND PLAN

- a. The Bidders must satisfy themselves as to the location of the Work, transportation facilities, soil conditions, underground conditions, groundwater, and all other matters, which may influence their Bids. It will be assumed that the Bidder has investigated and is satisfied as to the conditions to be encountered, as to the character, quality, and quantity of work to be performed and the material, equipment, and other devices to be furnished and as to the requirements of these Contract Documents.
- b. Any information derived from the District, or any of its/his employees or from any records of the District will not relieve the Contractor from risks of the responsibility of fulfilling the terms of the Contract.

6. MANDATORY PRE-BID MEETING

All general contractors who wish to submit a bid for this project must attend a mandatory pre-bid job walk through at the project site at 10:00 am on Thursday, April 21, 2022, with General Manager, Derek Schweigart. Bidders must email any questions to Mr. Schweigart at [generalmanager@highlandsrec.ca.gov](mailto:generalmanager@highlandsrec.ca.gov) no later than five working days prior to the bid opening. Responses to all questions will be sent to all bidders three working days before the bid opening. Bidders must follow all County and State health and safety guidance concerning appropriate social distancing and mask requirements during the site visit.

7. FILLING IN BID FORMS BY BIDDERS

- a. Bids shall be submitted on the Bid Forms included with the Contract Documents. Bidder shall submit, concurrently with its Bid:
  - i. Completed Bid Form,
  - ii. Signed Acknowledgement Form,
  - iii. Department of Industrial Relations and SB854 Compliance Affidavit (Located at end of this section)
  - iv. List of Subcontractors,
  - v. The Bidders Statement of Responsibility,
  - vi. Bidder's Non-Collusion Affidavit,
  - vii. Bid Guarantee,
  - viii. Certification by Contractor (Located at end of General Conditions), and
  - ix. All other information requested by these Contract Documents.

- b. All blanks on the Bid Forms shall be filled in by typewriter or printed legibly in ink.
- c. The Bidder must individually initial all interlineations, alterations, and erasures.
- d. Bidder shall acknowledge receipt of all Addenda on the Bid.
- e. Bidder shall not modify or qualify the Bid Forms in any manner.
- f. The Bid Forms shall be signed by a person or persons legally authorized to bind Bidder to the Contract. The individuals signing each document shall warrant that they are authorized to bind the legal entity of the Bidder.

8. ADDITIVE AND DEDUCTIVE ALTERNATES.

This bid solicitation includes additive or deductive items. Pursuant to Public Contract Code section 20103.8, the lowest bid shall be the lowest bid price on the base contract without consideration of the prices on the additive or deductive items. The District retains the right to add or deduct from the Contract any of the additive or deductive alternates included in the Bid.

9. BID GUARANTEE

- a. All Bids shall be accompanied by cash or a cashier's or certified check payable to the order of the Highlands Recreation District, amounting to ten percent (10%) of the bid, or by a bidder's bond in said amount executed by an admitted surety insurer and payable to the Highlands Recreation District (hereinafter "Security"). If the Bidder fails, within five (5) workdays after written notice that the Contract has been awarded to him, to enter a Contract with the Highlands Recreation District, the District may award the Contract to the second lowest Bidder. In such event, the amount of Bidder's Security shall be applied by the District to the difference between the Bidder's Bid and the second lowest Bid, and the surplus, if any, shall be returned to the Bidder if cash or a check is used, or to the surety on Bidder's bond if a bond is used.
- b. The Bid Security of the successful Bidder will be returned to them once a satisfactory Contract accompanied by the proper bonds is executed. The Bid Security of other Bidders will be returned to them upon the award of the Contract to the successful Bidder, except that of the next higher Bidder which shall be returned to him upon the execution of a satisfactory Contract accompanied by the proper bonds by the lowest Bidder, or in case of a default, the surety of the next higher Bidder will be held until they execute a satisfactory Contract accompanied by the proper bonds.

10. WITHDRAWAL OF BID

Any Bid may be withdrawn at any time prior to 8:00 a.m. of the day fixed in the "Notice Inviting Bids" for the opening of the Bids provided that a request in writing executed by the Bidder or his authorized agent for such withdrawal is filed with the Highlands Recreation District. The

withdrawal of any Bid shall not prejudice the right of a Bidder to file a new Bid prior to the established **10:00 a.m. deadline on April 29, 2022.**

11. RESPONSIBILITY OF BIDDER

- a. The District has absolute discretion to determine the lowest responsive, responsible Bidder. The Contract will not be awarded to any Bidder who cannot give satisfactory assurance of their ability to perform the Contract if it is awarded to them. Each Bidder may be required to furnish satisfactory evidence that he has sufficient means and facilities and has had ample experience in the type of work contemplated herein to deliver the materials and complete the installation in accordance with the specifications and within the time limit guaranteed.
- b. In determining whether or not a Bidder is “responsible,” the District may appoint a Representative to consider the following factors in relation to the Work to be performed for this Project:
  - i. Demonstrated financial strength including, but not limited to, resources available, bonding capacity, and available insurance.
  - ii. Demonstrated safety record including, but not limited to, Experience Modification Rate.
  - iii. Successful completion of a minimum of 2 projects of similar scope and size for playground installations for a period of 3-years. In reviewing this factor, the District may consider elements including, but not limited to, contract amount of completed projects, experience on public works projects for installation of playground structures, experience implementing prevailing wage certified payroll requirements, timeliness of performance, and, if necessary, evaluation of Bidder’s work by previous agencies, clients, design professionals, or subcontractors. Bidder shall provide names and phone numbers of references for similar projects.
  - iv. Sufficiency of contract administration and construction management systems including, but not limited to, proposed scheduling tools, proposed subcontract forms, proposed progress payment applications, and proposed certification of payroll documents.
  - v. History of claims, litigation, poor performance, late project completions, warranty issues and termination or disqualification from projects.
  - vi. History of claims, poor performance, late project completions, or warranty issues on previous District projects.

The District Representative will make its determination of responsibility based upon information submitted by Bidders contained in the “Bidders Statement of Responsibility,” included in the Contract Documents and, if necessary, interviews with previous public agencies, clients, design professionals, or subcontractors with whom the Bidder has worked.

If a Bidder otherwise determined to be the lowest responsive Bidder is determined to be non-responsible by the District Representative, that Bidder will be given written notice of each finding by the District Representative and shall have five (5) working days to present additional relevant evidence to the District Representative. The District



Representative shall make a recommendation to the District Board of Directors, which shall make a finding on the issue of non-responsibility as part of the process of Award of Contract.

- c. The Contractor shall possess a valid **California Class A or B Contractors License** at the time of award of the Contract. Bids will not be accepted from a Contractor who is not licensed in accordance with the laws of the State of California.

12. PROGRESS SCHEDULE – MATERIAL AND EQUIPMENT LISTS

The Contractor shall submit a progress schedule satisfactory to the District, within 10 working days after issuance of the Notice of Award to the Contractor showing thereof the time they propose to spend in executing the various major divisions of the work and his proposed sequence or order of operation. The schedule shall be updated monthly by the contractor. At a minimum the contractor shall provide a Gant chart with dates and duration for the following activities: Submittal of shop drawings and data, mobilization of equipment to the site, installation of temporary fencing to secure the work area and direct the public to other areas of the park, removal and off haul and disposal of existing structures, removal and storage of existing engineered wood fiber, fine grading of the playground under the engineered wood fiber to restore grades to conditions that existed prior to contractor's start of work, installation of playground and sports court equipment, lighting, shade structures and other park amenities including anticipated County inspection dates, repairs of existing equipment and structures where applicable, reinstalling of drainage fabric and drain rock where applicable, reinstallation of existing and new engineered wood fiber, resurfacing of sports court, touch-up painting, final clean-up, removal of temporary fencing, replacement of materials and any irrigation system damaged by contractor's activities and final inspection by County.

13. CONTRACT BONDS

The Contractor shall furnish bonds, at his own expense, to the extent required by law or as set forth in the Contract Documents.

14. INSURANCE

The Contractor shall provide, at his own expense, all insurance including, but not limited to, Workers' Compensation, Public Liability and Property Damage, required by law or as set forth in the General Conditions or the Contract.

15. AWARD OF CONTRACT

The District reserves the right to reject any or all Bids. The award of the Contract, if it is to be awarded, will be made to the lowest responsible Bidder whose Bid complied with all the prescribed requirements, and if awarded, after it has been approved by the Highlands Recreation District Board of Directors. The District reserves the sole right to reject any and all bids and waive any informality in a bid and may award a contract as the interests of the District may dictate. Contractors will not be reimbursed for the cost of bid preparation.

16. EXECUTION OF CONTRACT

- a. The Contract shall be executed and signed by the Contractor and returned with the prescribed executed bonds and evidence of insurance within the five- (5) working days after receipt by Contractor of the Notice of Award. Failure to return the signed and executed Contract with the prescribed executed bonds and insurance within the five (5) working day limit shall be just cause for the annulment of the award and the forfeiture of that portion of the Bid Security equal to the difference between Contractor's Bid amount and the amount submitted by the second lowest responsible Bidder.
- b. Contractor shall have an active business license with San Mateo County within 10 working days of Notice of Award.

17. SUBCONTRACTOR

Each Bidder must comply with Public Contract Code §§ 4100 - 4114 and following (Subletting and Subcontracting Fair Practices Act) and must submit with his Bid on the form attached to the Bid Forms, the name, the location of the place of business, the California contractor license number, and public works contractor registration number issued pursuant to Section 1725.5 of the Labor Code of each proposed subcontractor who will perform work or labor or render services to the Contractor in excess of one-half percent of the total Bid or, in the case of streets or highways, one-half percent or \$10,000, whichever is greater, and shall state the portion of the work which will be done by each subcontractor.

18. COMMENCEMENT OF WORK

The Work shall be commenced within five (5) working days after receipt of Notice to Proceed and must be completed within the time allowed after the date specified in the Notice to Proceed, or if no starting date is specified, within the time limit allowed from the date on which work started.

The successful bidder and its subcontractors shall employ workers, trades, and craftsmen which constantly display and demonstrate proper moral, safe, ethical, and professional conduct to all fellow workers, employees, and representatives of the District and other involved entities.

19. TAXES

The Bid price set forth in the Bid form shall include all Federal, State, and local taxes applicable to the Work or materials furnished and no claims for additional costs of any such tax shall be made.

20. SCHEDULE OF PRICES

The Contractor may be required to submit, upon award of Contract, a breakdown or schedule of unit prices which is satisfactory to the District to be used for monthly estimates.

21. COMPLIANCE WITH LABOR LAWS

- a. **In General.** For purposes of California labor law, this is a public works contract subject to the provisions of Part 7 of Division 2 of the California Labor Code (Sections 1720, et seq.). In accordance with Labor Code Section 1771, Contractor and all subcontractors shall pay not less than current prevailing wage rates as determined by the California Department of Industrial Relations (“DIR”) to all workers employed on this project. In accordance with Labor Code Section 1815, Contractor and all subcontractors shall pay all workers employed on this project 1 ½ the basic rate of pay for work performed in excess specified hour limitations. The work performed pursuant to this Contract is subject to compliance monitoring and enforcement by DIR.
- b. **Registration.** Contractor and all subcontractors shall not engage in the performance of any work under this Contract unless currently registered and qualified to perform public work pursuant to section 1725.5 of the California Labor Code. Contractor represents and warrants that it is registered and qualified to perform public work pursuant to section 1725.5 of the Labor Code and will provide its DIR registration number, along with the registration numbers of any subcontractors as required, to the District.
- c. **Report on Prevailing Rate of Wages.** The District has obtained the general prevailing rate of per diem wages in the vicinity of the project for each type of worker needed, a copy of which is on file at the Highlands Recreation District Offices, located at 1851 Lexington Ave., San Mateo, CA 94402, and shall be made available to any interested party upon request. Further, the general prevailing rate of per diem wages and the general prevailing rate for holiday and overtime work for each craft, classification, or type of worker needed to execute the Contract is available from the Director of the Department of Industrial Relations at: <http://www.dir.ca.gov/oprl/PWD/index.htm>.
- d. The District will not recognize any claim for additional compensation because of the payment by the Contractor of any wage rate in excess of the prevailing wage rates on file as aforesaid. The possibility of a wage increase is one of the elements to be considered by the Contractor in determining his/her or its bid and will not, under any circumstances, be considered as the basis of a claim against the District on the Contract.
- e. Bidders shall complete the attached Department of Industrial Relations and SB 854 Compliance Affidavit and submit with their Bid.

22. DISCREPANCIES IN BIDS

Where there is any discrepancy in the written or numerical quotation of unit bids or the extension of the quantities and unit prices, the products of the written quotation of unit price and the estimated quantity for the item will be the bid considered correct by the District.

23. DELIVERY OF BIDS

**Bids must be delivered to the Highlands Recreation District, 1851 Lexington Ave., San Mateo, CA 94402, up to but not later than 10:00 a.m., April 29, 2022.**

24. COMPLIANCE WITH BIDDING PROCESS

The Highlands Recreation District reserves the right to accept or reject any submitted Bid which fails to comply with any of the requirements as set forth herein.

**DEPARTMENT of INDUSTRIAL RELATIONS and SB 854 COMPLIANCE AFFIDAVIT**

In accordance with the California Labor Code as amended through Senate Bill SB 854, as a condition to bid on, be listed in a bid or perform work under a public works project, all Contractors are required to register, and maintain active registration throughout the duration of the contract with the California Department of Industrial Relations (DIR). This project is subject to compliance monitoring and enforcement by the Department of Industrial Relations. For information regarding registration, please go to:

<http://www.dir.ca.gov/public-works/PublicWorksSB854FAQ.html>

I, the Bidder, certify that:

"I am aware of the provisions of the Senate Bill SB 854 and subsequent DIR regulations, which require Contractors/Vendors to comply with all labor compliance requirements including but not limited to prevailing wage requirements, Labor Code sections 1725.5, 1771.1(a), 1774-1776, 1777.5, 1813, 1815, Public Works Contractor Registration Program, Electronic Certified Payroll Records to Labor Commissioner, and other requirements described in the DIR website. I am registered and qualified to perform public work pursuant to Labor Code section 1725.5 and I will comply all applicable provisions before commencing the performance of the work of this contract, and maintain compliance throughout the completion of said contract."

\_\_\_\_\_  
Signature

\_\_\_\_\_  
Date

\_\_\_\_\_  
Print Name

\_\_\_\_\_  
Business Name

\_\_\_\_\_  
Title

\_\_\_\_\_  
CSLB License Number

\_\_\_\_\_  
PWC Registration Number



# Highlands Recreation District

1851 Lexington Avenue • San Mateo, CA 94402

(650) 341-4251 • Fax (650) 349-9627

www.highlandsrec.ca.gov

*"A Community Place to Learn, Grow & Play"*

## CONTRACT

**THIS CONTRACT**, made and entered into the last date signed below ("Effective Date"), by and between the HIGHLANDS RECREATION DISTRICT, State of California, hereinafter referred to as the "District" or "Owner" and \_\_\_\_\_, hereinafter called the "Contractor,"

### WITNESSETH:

**THAT**, for and in consideration of the mutual covenants and agreements hereinafter contained, the parties hereto agree as follows:

**I.** The Contractor will at his own proper cost and expense, do all the work and furnish all the labor, materials, equipment, and utilities necessary to perform and complete in good workmanlike and substantial manner, and to the satisfaction of the General Manager of the Highlands Recreation District, the duly appointed representative of "Owner," for the project

### **HRD Playground and Sports Court Renovation Project**

and all in strict accordance with the Plans, Specifications, Notice Inviting Bids, and Bid Proposal on file in the office of the General Manager. The Contract Documents incorporated into this Contract include and are comprised of the following: Notice Inviting Bids, Bidder's Acknowledgment, Instructions for Bidders, Bid Proposal, Contract, General Conditions, Bonds, Contract Specifications, Drawings, Notice of Award, and Notice to Proceed, along with any

Addenda or Change Orders.

**II.** The CONTRACTOR will receive and accept, and the District will pay the prices specified in the Contractor's Bid Proposal, dated \_\_\_\_\_(DATE AND AMOUNT) as full compensation for furnishing all labor, materials and equipment for doing all the work contemplated and embraced in this Contract; the Contractor assumes any and all loss or damage arising out of the nature of the work aforesaid, or from the action of the elements, or from any unforeseen difficulties or obstructions which may arise or be encountered in the prosecution of the work until its acceptance by the District, and for all risks of every description connected with the work, and also assumes any and all expenses incurred by or in consequence of the suspension or discontinuance of work and for well and faithfully completing the work, and the whole thereof, in the manner and to the Plans, Specifications and Special Provisions and requirements of the Owner hereunder. The Contractor shall guarantee all materials and workmanship for a minimum period of two (2) years from date of acceptance of the project by the General Manager. Any defects due to faulty materials, method of installation or workmanship within that period shall be repaired by the Contractor promptly upon notice by the Owner, at the expense of the Contractor.

It is distinctly understood that the estimate set forth in the Notice Inviting Bids is only an approximation of the amount of work to be done and the District does not expressly or by implication agree that the actual amount of work will correspond with the amount set forth therein, and payment shall be made to the Contractor as above set forth.

**III.** Time is of the essence in the Contract, and the work to be performed hereunder shall be completed within the time frame outlined in the Notice to Proceed.

This Agreement is subject to termination as provided by Section 4410 and Section 4411

of the Government Code of the State of California, being portions of the Emergency Termination of Public Contracts Act of 1949. In the event that the Contract is terminated pursuant to said sections, compensation to the Contractor shall be determined on the basis of the reasonable value of the work done, including preparatory work. As an exception to the foregoing, in the case of any fully completed separate item or portion of the work for which there is a separate Contract price, the Contract price shall control.

**IV.** Relationship of the parties: Contractor agrees and understands that the work/services performed under this Agreement are performed as independent contractor and not as an employee of the District and that Contractor acquires none of the rights, privileges, powers, or advantages of District employees.

**V.** The Contractor shall comply with all existing and future state and federal and regulating laws and all ordinances and regulations of the County of San Mateo which in any manner affect those engaged or employed in the work, or the materials used in the work, or which in any way affect the conduct of the work, and of all such orders and decrees of bodies or tribunals having any jurisdiction or authority over the same.

**VI.** Neither party to the Contract shall assign the Contract or sublet it as a whole without written consent of the other, nor shall the Contractor assign any monies due or to become due to him hereunder without the previous written consent of the District. The Contractor shall neither mortgage nor convey title to equipment or material to be used in this work, without the written permission of the District.

**VII.** The District hereby promises and agrees with the said Contractor to employ and does hereby employ the said Contractor to provide the materials, unless otherwise specified, and to do the work according to the terms and conditions herein contained and referred to, for the prices



aforesaid and hereby contracts to pay the same at the time, in the manner and upon the conditions above set forth, and the said parties for themselves, their heirs, executors, administrators, successors, and assigns, do hereby agree to the full performance of the covenants herein contained.

**VIII. Retention of Records, Right to Monitor and Audit**

**A.** Contractor shall maintain all required records for three (3) years after the District makes final payment and all other pending matters are closed, and shall be subject to the examination and/or audit of the District, County, a Federal grantor agency, and the State of California.

**B. Reporting and Record Keeping:** Contractor shall comply with all program and fiscal reporting requirements set forth by appropriate federal, state, and local agencies and as required by the District.

**C.** Contractor agrees to provide to District, to any federal or state department having monitoring or review authority, to District's authorized representatives, and/or their appropriate audit agencies upon reasonable notice, access to and the right to examine all records and documents necessary to determine compliance with federal, state, and local statutes, rules and regulations, and this Contract, and to evaluate the quality, appropriateness and timeliness of services performed.

**IX. Merger Clause:** This Contract, including the Contract Documents, constitutes the sole Contract of the parties hereto and correctly states the rights, duties, and obligations of each party as of this document's date. Any prior agreement, promises, negotiations, or representations between the parties not expressly stated in this document are not binding. All subsequent modifications shall be in writing and signed by the parties.

**X.** Controlling Law: The validity of this Contract and of its terms or provisions, as well as the rights and duties of the parties hereunder, the interpretation, and performance of this Contract shall be governed by the laws of the State of California.

**XI.** Notices: Any notice, request, demand, or other communication required or permitted hereunder shall be deemed to be properly given when deposited in the United States mail, postage prepaid, or when deposited with a public telegraph company for transmittal, charges prepaid, addressed to:

**In the case of District, to:**

Derek Schweigart, General Manager  
Highlands Recreation District  
1851 Lexington Ave  
San Mateo, CA 94402

**In the case of Contractor, to:**

Contractor Name:

Contractor Address:

**XII.** In no event, shall the compensation paid to Contractor by District under this Agreement exceed the amount of **DOLLAR AMOUNT WRITTEN OUT (DOLLAR AMOUNT)**, unless approved by the Board of Directors pursuant to a supplemental agreement.

**IN WITNESS WHEREOF**, the parties to these presents have hereunto set their hands the year and date first above written.

**“District”** Highlands Recreation District,  
State of California

BY: \_\_\_\_\_  
**Derek Schweigart, General Manager**

**“Contractor”** **NAME OF CONTRACTOR HERE**

BY: \_\_\_\_\_  
(Authorized Signature and Seal of Bidder)

BY: \_\_\_\_\_  
(Authorized Signature and Seal of Bidder)

If Contractor is a corporation, signatures of two officers of the corporation are required per Cal. Corporation Code sec. 313.

**GENERAL CONDITIONS  
FOR  
Highlands Recreation District Playground and Sports Court Renovation Project**

1-01 DEFINITIONS

- a. The Contract Documents consist of the Contract Documents identified in the Contract.
- b. The Owner and the Contractor are those mentioned as such in the Contract. They are treated throughout the complete Contract and the Contract Documents as if each were of the singular number and masculine gender.
- c. The term Subcontractor, as employed herein, includes only those having a direct contract with the Contractor and it includes one who furnishes material worked to a special design according to the drawings and specifications of this work, or labor at the site, but does not include one who merely furnishes material not so worked.
- d. Where in any of the Contract Documents or in the complete Contract there is any provision in respect to the giving of any notice, such notice shall be deemed to have been given (as to the Owner) when written notice shall have been placed in the United States mail addressed to the Owner at its place of business; (as to the Contractor) when written notice shall be delivered to the chief representative of the Contractor at the site of the Project or by mailing such written notice in the United States mail addressed to the Contractor at the place stated in the papers prepared by him to accompany his bid as the address of his permanent place of business.
- e. The term “work” of the Contractor or Subcontractor includes labor or materials or both.
- f. All time limits stated in the Contract Documents are of the essence of the Contract.

1-02 EXECUTION, CORRELATION, AND INTENT OF DOCUMENT

The Contract Documents are complementary, and what is called for by anyone shall be as binding as if called for by all. The intention of the documents is to include in the Contractor’s Bid the costs of all labor and materials, equipment, and transportation necessary for the proper execution of the work. Materials or work described in words, which so applied, have a well-known technical or trade meaning shall be held to refer to such recognized standards.

1-03 DETAIL DRAWINGS AND INSTRUCTION

- a. The Engineer, if there is one, shall prepare and file either complete and accurate plans and specifications or a work authorization describing the work to be performed, together with an estimate of the cost thereof, prior to commencement of the work.
- b. The Engineer if there is one, shall furnish with reasonable promptness, additional instructions, by means of drawings or otherwise, necessary for the proper execution of the work. All such drawings and instructions shall be consistent with the Contract Documents, true developments thereof and reasonably inferable therefrom.

- c. The work shall be executed in conformity therewith and the Contractor shall do no work without proper drawings and instructions.

#### 1-04 SUBMITTALS

The Contractor shall check and verify all field measurements and submit prior to commencing work and with such promptness as to cause no delay in his own work or in that of any other Contractor, one (1) copy in electronic PDF format of all shop, product or setting drawings and schedules required for the work of the various trades, and the Owner, or the Engineer, if there is one, shall return within 14 days, making desired corrections, including all necessary corrections relating to artistic effect. The Contractor shall make any corrections required by the Owner, or the Engineer, if there is one, and file with him one (1) electronic PDF format corrected copy and furnish such other copies as may be needed. The approval of such drawings or schedules by the Owner, or the Engineer, if there is one, shall not relieve the Contractor from responsibility for deviations from drawings or specifications, unless he has, in writing, secured approval by the Owner, or the Engineer, if there is one, of such deviations, nor shall it relieve Contractor from responsibility for errors of any sort in shop drawings or schedules.

Shop drawings and submittals shall also comply with the technical specifications for the project.

Contractor agrees that Shop Drawing Submittals processed by the Owner, or the Engineer, if there is one, are not Change Orders; that the purpose of Shop Drawing Submittals by the Contractor is to demonstrate to the Owner, or the Engineer, if there is one, that the Contractor understands the design concept, that he demonstrates his understanding by indicating which equipment and material he intends to furnish and install and by detailing the fabrication and installation methods he intends to use.

Contractor further agrees that if deviations, discrepancies or conflicts between Shop Drawings and Specifications are discovered either prior to or after Shop Drawing Submittals are processed by the Owner, or the Engineer, if there is one, the design Drawings and Specifications shall control and shall be followed.

- a. Unless otherwise stipulated, the Contractor shall provide and pay for all materials, labor, water, tools, equipment, light, power, transportation, and other facilities necessary for the execution and completion of the work.
- b. Unless otherwise specified, all materials shall be new and both workmanship and materials shall be of good quality. The Contractor shall, if required, furnish satisfactory evidence as to the kind and quality of materials.
- c. The Contractor shall employ on the work only workmen skilled in the work assigned to them, and the Owner shall have the right to require the removal from this work of any employee unacceptable to Owner.

#### 1-05 ROYALTIES AND PATENTS

The Contractor shall pay all royalties and license fees. He shall defend all suits or claims for infringement of any patent rights and shall save the Owner harmless from loss on account thereof, except that the Owner shall be responsible for all such loss when a particular process or the product of a particular manufacturer or manufacturers is specified, but if the Contractor has information that the process or article specified is an infringement of a patent he shall be responsible for such loss unless he promptly gives such information to the Owner, or the Engineer, if there is one. The approval of any method of construction, invention, appliance, process, article, device, or material of any kind by the Owner, or the Engineer, if there is one, shall only be an approval of its adequacy for the work and shall not be an approval of the use thereof by the Contractor in violation of any patent or other rights of any third person.

1-06 PERMITS, REGULATIONS AND TAXES

- a. Contractor must obtain and pay for all permits, fees, or licenses required to perform the work, except as outlined in the bid sheet. Contractor must cooperate with and provide notifications to all government agencies with jurisdiction over the Project, as may be required. Contractor must provide Owner with copies of all notices, permits, licenses, and renewals required for the Work. Contractor shall administer coordination of the permit and schedule and attend inspections as required by San Mateo County. Any cost of re-inspections shall be paid for by the Contractor. Contractor shall maintain all licenses necessary for the execution of the work shall be secured and paid for by the Contractor unless otherwise specified.
- b. The Contractor shall give all notices and comply with all laws, ordinances, rules and regulations bearing on the conduct of the work as drawn and specified. If the Contractor observes that the drawings and specifications are at variance therewith he shall promptly notify the Owner, or the Engineer, if there is one, in writing, and any necessary changes shall be adjusted as provided in the contract documents for changes in the work. The Contractor shall not proceed with the performance of any such work until such changes are agreed upon. If the Contractor performs any work knowing it to be contrary to such laws, ordinances, rules, and regulations, without such notice to the Owner, or the Engineer, if there is one, and such adjustments of changes as aforesaid, then the Contractor shall bear all costs arising from or in connection with such work.
- c. The Contractor shall pay for all federal, state, and local taxes on all materials and labor services furnished by him and all taxes arising out of the operations under this contract.

1-07 PROTECTION OF WORK AND PROPERTY

The Contractor shall continuously maintain adequate protection of all his work from damage and shall protect the Owner's property from injury or loss arising in connection with this Contract. He shall make good any such damage, injury, or loss, except such as may be directly due to errors in the Contract Documents or caused by agents or employees of the Owner. He shall adequately protect adjacent property as provided by law and the Contract Documents, and shall make good any damage, injury or loss thereto arising in connection with this Contract.

1-08 ACCIDENT PREVENTION

Precaution shall be always exercised for the protection of persons (including employees) and property. The safety provisions of applicable laws, building and construction codes shall be observed. Machinery and equipment shall be guarded, and all hazards eliminated in accordance with the safety provisions of the Manual of Accident Prevention in Construction, published by the Associated General Contractors of America, to the extent that such provisions are not in contravention of applicable law.

#### 1-09 INSPECTION OF WORK

- a. The Engineer, if there is one, and his representatives, and/or the Owner's representatives shall, always, have access to the work and the Contractor shall provide proper facilities for such access and for inspection.
- b. Re-examination of questioned work may be ordered by the Owner, or the Engineer, if there is one, and, if so ordered, the work must be uncovered by the Contractor. If such work were found in accordance with the Contract Documents, the Owner shall pay the cost of reexamination and replacement. If such work be found not in accordance with the Contract Documents, the Contractor shall pay such costs, unless he shall show that the defect in the work was caused by some other contractor for whose work the Contractor herein is not responsible and, in that event, the Contractor herein shall not be liable for such cost.
- c. All work shall be under the direct inspection of the Owner, or the Engineer, if there is one. All work shall also be subject to all necessary and required inspections of the Highlands Recreation District and the County of San Mateo. No work shall be covered until it has been inspected by the Owner, or the Engineer, if there is one.

#### 1-10 CONTRACTOR'S SUPERINTENDENCE AND SUPERVISION

- a. Contractor shall keep on his work, during its progress, a competent superintendent, and any necessary assistants, all-satisfactory to the Owner, or the Engineer, if there is one. The Superintendent shall not be changed except with the consent of the Owner, or the Engineer, if there is one, unless the Superintendent proves to be unsatisfactory to the Contractor and ceases to be in his employ, or unless the Superintendent proves to be unsatisfactory to the Owner. The Superintendent shall represent the Contractor in his absences and all directions given to him shall be as binding as if given to the Contractor. Other directions shall be so confirmed on written request in each case.
- b. The Contractor shall give efficient supervision to the work, using his best skill and attention. He shall carefully study and compare all drawings, specifications and other instructions and shall at once report to the Owner, or the Engineer, if there is one, any error, inconsistency, or omission which he may discover, but he shall not be held responsible for their existence or discovery.
- c. The Contractor shall be specifically responsible for the coordination of all work performed under this Contract. Coordination of the work shall be interpreted to include general laying out of the structures, coordination of the layout and work under various sections, scheduling the sequence of operations ensuring cooperation between the

trades, and the preparation of erection diagrams and drawings necessary to ensure proper and expeditious completion of all work.

- d. Each Subcontractor shall be responsible for the proper laying out of his own work, shall coordinate his layout and work with the work of the other sections and shall be responsible for any damage which may occur to the work of any other Subcontractor or Contractor because of errors or inaccuracy. Neither the Owner, nor the Engineer, if there is one, nor their representatives, will, in any case, assume the responsibility for laying out the work.

#### 1-11 CHANGES IN THE WORK

- a. The Owner, without invalidating the Contract, may order extra work or make changes by altering, adding to, or deducting from the work in writing, the Contract Sum being adjusted accordingly. All such work shall be executed under the conditions of the original Contract except that any claim for extension of time caused thereby shall be adjusted at the time of ordering such change.
- b. In giving instructions, the Owner, or the Engineer, if there is one, shall have authority to make minor changes in the work, not involving extra costs, and not inconsistent with the purposes of the building, but otherwise, except in an emergency endangering life or property, no extra work or change shall be made unless in pursuance of a written order signed by the Owner and countersigned by the Engineer, if there is one. No claim for an addition to the contract sum shall be valid except for work ordered in writing.
- c. The value of any such extra work or change shall be determined in one of the following ways:
  - i. By unit prices contained in the original bid.
  - ii. By an acceptable lump sum proposal.
  - iii. On a cost-plus limited percentage basis (defined as cost of direct labor, materials, and insurance plus a specified percentage of these items, but not to exceed 15% of the aggregate of the cost of such direct labor, materials, and insurance as an allowance for overhead and profit. The contractor's allowance for overhead and profit on subcontractor costs shall not exceed 5%. Sub-contractors shall be permitted a 10% allowance for overhead and profit on their similar direct costs).
- d. If none of the above is agreed upon, the Contractor, provided he receives an order as above, shall proceed with the work. In such case, he shall keep and present a correct account of the cost, together with vouchers, and the Owner, or the Engineer, if there is one, shall thereupon certify the amount due for such work, including a 15% allowance for the Contractor's overhead and profit and a 10% allowance for any of his Sub-Contractors overhead and profit.

#### 1-12 CLAIMS FOR EXTRA COST



All claims for extension or extra costs of \$375,000 or less which are not resolved by change order shall be resolved in accordance with Public Contract Code Section 20104 and following, a copy of which is attached to these General Conditions.

1-13 DEDUCTIONS FOR UNCORRECTED WORK

If the Owner, and the Engineer, if there is one, deem it inexpedient to correct work injured or done not in accordance with the Contract, an equitable deduction from the contract price shall be made therefor.

1-14 DELAYS AND EXTENSION OF TIME

- a. If the Contractor be delayed at any time in the progress of the work by an act or neglect of the Owner, or the Engineer, if there is one, or of any employee of either, or by any separate Contractor employed by the Owner, or by changes ordered in the work or by strikes, lockouts, fire, unusual delay in transportation, unavoidable casualties or any cause beyond the Contractor's control, or by any cause which the Owner or Engineer shall decide justifies the delay, then the time of completion shall be extended for such reasonable time as the Owner or Engineer may decide but only to the extent that the delay affects critical path items for completing the work by the completion date.
- b. No such extension shall be made for delay occurring more than seven (7) days before claim therefor is made in writing to the Owner, or to the Engineer, if there is one. In the case of a continuing cause of delay, only one claim is necessary.
- c. If no schedule or agreement stating the dates upon which drawings shall be furnished is made, then no request for delay shall be allowed on account of failure to furnish drawings until two weeks after demand for such drawings and not then unless such request be reasonable.

1-15 CORRECTIONS OF WORK BEFORE FINAL PAYMENT

- a. The Contractor shall promptly remove from the premises all materials condemned by the Owner, or the Engineer, if there is one, as failing to conform to the Contract, whether incorporated in the work or not, and the Contractor shall promptly replace and re-execute his own work in accordance with the Contract and without expense to the Owner and shall bear the expense of making good work of other contractors destroyed or damaged by such removal or replacement.
- b. If the Contractor does not remove such condemned work and materials within a reasonable time, fixed by written notice, the Owner may remove them and may store the material at the expense of the Contractor.

1-16 CORRECTION OF WORK AFTER FINAL PAYMENT

Neither the final certificate nor payment nor any provision in the Contract Documents shall relieve the Contractor of responsibility for faulty materials or workmanship, and, unless otherwise specified, he shall, within 14 days of receiving notice by the Owner, remedy any

defects due thereto and pay for any damage to their work resulting therefrom which shall appear within a period of two (2) years from the date of the acceptance by the Owner, at no expense to the Owner. The Owner shall give notice of observed defects with reasonable promptness. All questions arising under this article shall be decided by the Engineer, if there is one, subject to the right of either party to obtain judicial review.

#### 1-17 OWNER'S RIGHT TO DO WORK

If the Contractor should neglect to execute the work properly or fail to perform any provisions of the Contract, the Owner, after three days written notice to the Contractor, may without prejudice to any other remedy he may have, make good such deficiencies and may deduct the cost thereof from the payment then or thereafter due the Contractor; provided, however, that the Engineer, if there is one, shall approve both such action and the amount charged the Contractor.

#### 1-18 PAYMENT

- a. The Owner will cause partial payment to be made to the Contractor as provided in the Construction Contract based on a duly certified approved estimate of the work completed as of the last day of the preceding calendar month pursuant to this contract. These estimates will be prepared by the Contractor and shall meet the approval of the Owner, or by the Engineer, if there is one. Each application for payment must be itemized to include labor, materials, and equipment incorporated into the work, and materials and equipment delivered to the work site, as well as authorized and approved Change Orders. Each pay application must be supported by Contractor's Bid Proposal or any other substantiating data required by the Contract Documents.
- b. The Owner will pay the undisputed amount due within 30 days after Contractor has submitted a complete and accurate payment application, subject to Public Contract Code section 20104.50. Owner may deduct a percentage from each progress payment as retention, as set forth in Section 1-18(d), below, and may withhold additional amounts as set forth in Section 1-18(c), below.
- c. The Owner may adjust or reject the amount of payment requested in the payment application in whole or in part if the amount requested is disputed or unsubstantiated. The Owner will notify the Contractor in writing of the basis for any adjustment or rejection. The Owner may also deduct or withhold payments based on any of the following circumstances:
  - i. For Contractor's unexcused failure to perform the work as required by the Contract Documents, the Owner may withhold or deduct the amount the Owner estimates is necessary to correct or complete the work;
  - ii. For loss or damage caused by Contractor or its Subcontractors arising out of or relating to performance of the work or any failure to protect the work site, the Owner may deduct an amount based on the estimated cost to repair or replace;
  - iii. For Contractor's failure to pay Subcontractors or suppliers, the Owner may withhold an amount equal to the past due payments;

- iv. For Contractor's failure to timely correct rejected, nonconforming, or defective work, the Owner may withhold or deduct an amount based on the Owner's estimated cost to correct or complete the work;
  - v. For fines assessed under the Labor Code, as required by law; or
  - vi. For any other costs or charges that may be withheld, deducted from, or offset against payments due, as provided in the Contract Documents, including liquidated damages.
- d. The Owner will retain five percent of the amount due on each progress payment as retention to ensure full and satisfactory performance of the work.
  - i. As provided by Public Contract Code section 22300, Contractor may request in writing that it be allowed, at its sole expense, to substitute securities for the retention. Any escrow agreement entered into pursuant to this provision must fully comply with Public Contract Code section 22300, and will be subject to approval as to form by the Owner's legal counsel.
  - j. All undisputed retention, less any amounts that may be assessed as liquidated damages, or otherwise withheld under Section 1-18(c), will be released as Final Payment to Contractor no sooner than 35 days following recordation of the notice of completion, and no later than 60 days following acceptance of the Project by the Owner's governing body or authorized designee, or, if the Project has not been accepted, no later than 60 days after the Project is otherwise considered complete under Public Contract Code section 7107(c).

#### 1-19 CONTRACTOR'S INSURANCE

- a. **Insurance Required.** No later than ten (10) days following issuance of the Notice of Award, Contractor must procure and provide proof of the insurance coverage required by this Section in the form of certificates and endorsements acceptable to Owner. The required insurance must cover the activities of Contractor and its Subcontractors relating to or arising from the performance of the Work and must remain in full force and effect at all times during the period covered by the Contract, through the date of Owner's acceptance of the Project. If Contractor fails to provide any of the required coverage in full compliance with the requirements of the Contract Documents, Owner may, at its sole discretion, purchase such coverage at Contractor's expense and deduct the cost from payments due to Contractor, or terminate the Contract for default. The procurement of the required insurance will not be construed to limit Contractor's liability under this Contract or to fulfill Contractor's indemnification obligations under this Contract.
- b. **Acceptability of Insurers.** Insurance must be issued by insurers acceptable to Owner and licensed to do business in the State of California, and each insurer must have an A.M. Best's financial strength rating of "A" or better and a financial size rating of "VII" or better.
- c. **Policies and Limits.**
  - i. **Commercial General Liability ("CGL"):** Insurance Services Office (ISO) Form CG 00 01 covering CGL on an "occurrence" basis, written on a

comprehensive general liability form, and must include coverage for liability arising from Contractor's or Subcontractor's acts or omissions, including Contractor's protected coverage, blanket contractual, products and completed operations, vehicle coverage and employer's non-ownership liability coverage, with limits of at least **\$2,000,000** per occurrence. The CGL policy must protect against any and all liability for personal injury, death, property damage or destruction, and personal and advertising injury. If a general aggregate limit applies, either the general aggregate limit shall apply separately to this project/location (ISO CG 25 03 or 25 04) or the general aggregate limit shall be twice the required occurrence limit.

- ii. **Automobile Liability:** ISO Form CA 00 01 covering any auto (Code 1), or if Contractor has no owned autos, then hired autos (Code 8) and non-owned autos (Code 9), with limit no less than **\$1,000,000** per accident for bodily injury and property damage.
- iii. **Workers' Compensation:** As required by the State of California, with Statutory Limits, and Employer's Liability Insurance of no less than **\$1,000,000** per accident for bodily injury or disease, or as otherwise required by statute. If Contractor is self-insured, Contractor must provide a Certificate of Permission to Self-Insure, duly authorized by the DIR.
- iv. **Builder's Risk.** Course of Construction insurance utilizing an "All Risk" (Special Perils) coverage form, with limits equal to the completed value of the project and no coinsurance penalty provisions.

Contractor may submit Builder's Risk insurance in the form of Course of Construction coverage, which shall **name the Owner as a loss payee**, as its interest may appear. The Builder's Risk policy must be issued on an occurrence basis, for all-risk coverage on a 100% completed value basis on the insurable portion of the Project, with no coinsurance penalties, and for the benefit of Owner. If the Project does not involve new or major reconstruction, Owner may elect, acting in its sole discretion, to accept an Installation Floater policy instead of Builder's Risk. For such projects, the Property Installation Floater shall include improvement, remodel, modification, alteration, conversion or adjustment to existing buildings, structures, processes, machinery, and equipment, and shall provide property damage coverage for any building, structure, machinery or equipment damaged, impaired, broken, or destroyed during the performance of the Work, including during transit, installation, and testing at the Owner's site.

d. **General Insurance Requirements**

- i. **Broader Coverage.** If Contractor maintains broader coverage and/or higher limits than the minimums shown above, Owner requires and shall be entitled to the broader coverage and/or higher limits maintained by the contractor. Any available insurance proceeds in excess of the specified minimum limits of

insurance and coverage shall be available to the Owner.

- ii. **Self-Insured Retentions.** Self-insured retentions must be declared to and approved by Owner. At Owner's option, either: (1) Contractor shall cause the insurer to reduce or eliminate self-insured retentions as respects Owner, its officers, officials, employees, and volunteers; or (2) Contractor shall provide a financial guarantee satisfactory to Owner guaranteeing payment of losses and related investigations, claim administration, and defense expenses. The policy language shall provide, or be endorsed to provide, that the self-insured retention may be satisfied by either the named insured or the Owner.
- iii. **Additional Insured Status.** The Highlands Recreation District, its Board of Directors, officers, officials, employees, agents, servants, and volunteers are to be covered as additional insureds on the CGL and automobile liability policies with respect to liability arising out of the work performed by or on behalf of Contractor including materials, parts, or equipment furnished. Endorsement of CGL coverage shall be at least as broad as ISO Form CG 20 10 11 85 or if not available, through the addition of **both** CG 20 10, CG 20 26, CG 20 33, or CG 20 38; and CG 20 37 if a later edition is used.
- iv. **Primary Coverage.** For any claims related to this Project, Contractor's insurance coverage shall be "**primary and non-contributory**" and at least as broad as ISO CG 20 01 04 13 with respect to Highlands Recreation District, its officers, officials, employees and volunteers, and shall not seek contribution from the District's insurance. If the limits of insurance are satisfied in part by **Umbrella/Excess Insurance**, the Umbrella/Excess Insurance shall contain or be endorsed to contain a provision that such coverage shall also apply on a "primary and non-contributory" basis for the benefit of the District.
- v. **Notice of Cancellation.** Each insurance policy required shall provide that coverage shall not be canceled, except with notice to Owner. Each certificate of insurance must state that the coverage afforded by the policy is in force and will not be reduced, cancelled or allowed to expire without at least thirty (30) days advance written notice to Owner, unless due to non-payment of premiums, in which case ten (10) days advance written notice must be provided to Owner. Such notice must be sent to Owner via certified mail.
- vi. **Waiver of Subrogation.** Each required policy must include an endorsement providing that the carrier agrees to waive any right of subrogation it may have against Owner. Contractor agrees to waive rights of subrogation which any insurer of Contractor may acquire from Contractor by virtue of the payment of any loss. Contractor agrees to obtain any endorsement that may be necessary to affect this waiver of subrogation. The Workers' Compensation policy shall be endorsed with a waiver of subrogation in favor of the Owner for all work

performed by the Contractor, its employees, agents, and subcontractors.

- vii. **Verification of Coverage.** Contractor shall furnish the Owner with original certificates and amendatory endorsements, or copies of the applicable insurance language, effecting coverage required by this contract. All certificates and endorsements are to be received and approved by the Owner before work commences. The Owner reserves the right to require complete, certified copies of all required insurance policies, including endorsements, required by these specifications, at any time.
- viii. **Subcontractors.** Contractor shall require and verify that all subcontractors maintain insurance meeting all the requirements stated herein, and Contractor shall ensure that Owner is an additional insured on insurance required from subcontractors. For CGL coverage, subcontractors shall provide coverage with a form at least as broad as CG 20 38 04 13.
- ix. **Surety Bonds.** Contractor must provide Payment and Performance Bonds in a sum equal to the Contract Price. If the Performance Bond provides for a one-year warranty, a separate Maintenance Bond is not necessary. However, if the warranty period specified in the Contract is for longer than one year a Maintenance Bond equal to 10% of the Contract Price is required. Bonds shall be duly executed by a responsible corporate surety, authorized to issue such bonds in the State of California and secured through an authorized agent with an office in California.
- x. **Special Circumstances.** Owner reserves the right to modify these requirements, based on the nature of the risk, prior experience, insurer, coverage, or other circumstances.

## 1-20 INDEMNIFICATION OF OWNER AND ENGINEER

To the fullest extent permitted by law, Contractor agrees to protect, defend, indemnify, and hold harmless the Owner, its board, officers, officials, employees, agency, volunteers, and consultants (the "Indemnitees") from and against all liability, loss, damage, claim, cause of action, demand, charge, cost, or expense (including attorneys' fees and related costs) (together, "Claims") of every nature arising out of or in connection with the performance of this Contract whether before or after completion, by Contractor or Contractor's agents, employees, Subcontractors, or anyone acting under Contractor's control, except such Claims arising from the sole negligence, active negligence, or the willful misconduct of an Indemnitee. This indemnity requirement applies to any Claim arising from alleged defects in the content or manner of submission of Contractor's bid for the Contract. Contractor's failure or refusal to timely accept a tender of defense pursuant to this Contract will be deemed a material breach of the Contract. Owner will timely notify Contractor upon receipt of any third-party claim relating to the Contract, as required by Public Contract Code section 9201. Contractor's indemnity

obligations under this Contract will survive the expiration or any early termination of the Contract.

#### 1-21 SURETY BONDS

The Contractor shall furnish bonds covering the faithful performance of the Contract (Performance Bond) and the payment of all obligations arising thereunder (Payment Bond), each in the amount of one hundred percent (100%) of the estimate amount, as stated in the Contract and in such form as the Owner may prescribe and with such sureties as he may approve. The Contractor shall pay the cost of the premium.

#### 1-22 LABOR COMPLIANCE

- a. **In General.** For purposes of California labor law, this is a public works contract subject to the provisions of Part 7 of Division 2 of the California Labor Code (Sections 1720, et seq.). In accordance with Labor Code Section 1771, Contractor and all subcontractors shall pay not less than current prevailing wage rates as determined by the California Department of Industrial Relations (“DIR”) to all workers employed on this project. In accordance with Labor Code Section 1815, Contractor and all subcontractors shall pay all workers employed on this project 1 ½ the basic rate of pay for work performed in excess specified hour limitations. The work performed pursuant to this Contract is subject to compliance monitoring and enforcement by the DIR.
- b. **Registration.** Contractor and all subcontractors shall not engage in the performance of any work under this Contract unless currently registered and qualified to perform public work pursuant to section 1725.5 of the California Labor Code. Contractor represents and warrants that it is registered and qualified to perform public work pursuant to section 1725.5 of the Labor Code and will provide its DIR registration number, along with the registration numbers of any subcontractors as required, to the Owner.
- c. **Posting.** Contractor shall post at the job site the determination of the DIR director of the prevailing rate of per diem wages together with all job notices that are required by regulations of the DIR.
- d. **Reporting.** Contractor and any subcontractors shall keep accurate payroll records in accordance with Section 1776 of the Labor Code and shall furnish the payroll records directly to the Labor Commissioner in accordance with the law.
- e. **Report on Prevailing Rate of Wages.** Owner has obtained the general prevailing rate of per diem wages in the vicinity of the project for each type of worker needed, a copy of which is on file at the Highlands Recreation District Offices, located at 1851 Lexington Ave., San Mateo, CA 94402, and shall be made available to any interested party upon request. Further, the general prevailing rate of per diem wages and the general prevailing rate for holiday and overtime work for each craft, classification, or type of worker needed to execute the Contract is available from the Director of the Department of Industrial Relations at: <http://www.dir.ca.gov/oprl/PWD/index.htm>.

- f. **Employment of Apprentices.** Contractor's attention is directed to the provisions in Sections 1777.5 and 1777.6 of the Labor Code concerning the employment of apprentices by the Contractor or any subcontractor. It shall be the responsibility of the Contractor to effectuate compliance on the part of itself and any subcontractors with the requirements of said sections in the employment of apprentices. Information relative to apprenticeship standards, wage schedules, and other requirements may be obtained from the Director of Industrial Relations, ex-officio the Administrator of Apprenticeship, San Francisco, California, or from the Division of Apprenticeship Standards and its branch offices.
- g. **Penalties, Generally.** Contractor's attention is directed to provisions in Labor Code Sections 1775 and 1813. In accordance with Labor Code Section 1775, Contractor and subcontractors may be subject to penalties for Contractor's and subcontractors' failure to pay prevailing wage rates. In accordance with Labor Code Section 1813, Contractor or subcontractors may be subject to penalties for Contractor's or subcontractors' failure to pay overtime pay rates for hours worked by workers employed on this project in excess specified hour limitations.
- h. **Penalties to District.** Contractor must compensate workers who are paid less than prevailing wages or required to work more than a legal day's work. Contractor will also be required to pay the District a penalty of \$200 per worker for each day of violation.

#### 1-23 DAMAGES

- a. Contractor bears the burden of proving entitlement to and the amount of any claimed damages. Contractor is not entitled to damages calculated on a total cost basis but must prove actual damages. Contractor is not entitled to consequential damages, including home office overhead or any form of overhead not directly incurred at the Worksite; lost profits; loss of productivity; lost opportunity to work on other projects; diminished bonding capacity; increased cost of financing for the Project; extended capital costs; non-availability of labor, material, or equipment due to delays; or any other indirect loss arising from the Contract. The Eichleay Formula or similar formula may not be used for any recovery under the Contract.
- b. Should the Contractor fail to complete the work included in the Contract within the time limit agreed upon or such extensions thereof as may be granted, a deduction of One Hundred and Fifty dollars (\$200) per day will be made from amounts otherwise due the Contractor for each calendar day, or fraction thereof, that the work, or each stated portion, remains incomplete after the date set for its completion.
- c. Claims under this clause shall be made in writing to the party liable within a reasonable time after the first observance of such damage and not later than the time of final payment, except as otherwise provided in the Contract Documents in the case of faulty work or materials.

#### 1-24 TRANSFER OF CONTRACT



The Contractor shall not transfer or assign this Contract without the approval of the Owner. No transfer or assignment shall, under any circumstances relieve the Contractor of his liabilities and obligations under this Contract. No transfer shall be made until after the Surety has been given due notice of such transfer and has furnished written consent thereto.

1-25 SEPARATE CONTRACTS

The Owner reserves the right to let other contracts in connection with this work. The Contractor shall afford other contractors reasonable opportunity for the introduction and storage of their materials and the execution of their work, and shall properly connect and coordinate his work with theirs.

1-26 SUBCONTRACTORS

- a. The Contractor shall submit with the Bid a list of all subcontractors who will perform work more than one-half percent of the total bid or, in the case of streets or highways, one-half percent or \$10,000, whichever is greater, and the Contractor shall not employ any that the Owner, or Engineer, if there is one, may within a reasonable time object to as incompetent or unfit.
- b. The Contractor agrees that he is fully responsible to the Owner for the acts and omissions of his Subcontractors and of persons either directly or indirectly employed by them, as well as for the acts and omissions of persons directly employed by him.
- c. Nothing contained in the Contract Documents shall create any contractual relation between any Subcontractor and the Owner.

1-27 ENGINEER'S STATUS

- a. The Engineer, if there is one, shall have general supervision and direction of the work as provided in his Contract with the Owner. He is an agent of the Owner only to the extent provided in the Contract Documents and when in special instances he is authorized by the Owner so to act, and in such instances he shall, upon request, show the Contractor written authority. He has authority to stop the work whenever such stoppage maybe necessary to insure the proper execution of the Contract.
- b. As the Engineer, if there is one, is in the first instance, the interpreter of the conditions of the Contract and the judge of its performance he shall side neither with the Owner nor with the Contractor but shall use his powers under the Contract to enforce its faithful performance by both.

1-28 ENGINEER'S DECISIONS

- a. The Engineer, if there is one, shall, within a reasonable time, make decisions on all claims of the Owner or Contractor and on all other matters relating to the execution and progress of the work or the interpretation of the Contract Documents.
- b. The decisions of the Engineer, if there is one, in matters relating to artistic effect, shall be final, if within the terms of the Contract Documents.

1-29 DISPUTES

Any disputes, claims or questions with a value of \$375,000 or less arising under the Contract or any documents thereof shall be resolved pursuant to PCC §§ 20104 – 20104.6, attached hereto.

1-30 CALIFORNIA OCCUPATIONAL SAFETY AND HEALTH ACT

Contractor shall adhere to all provisions of the California Occupational Safety and Health Act of 1973 (CALOSHA) as amended.

1-31 TRENCHING REQUIREMENTS

- a. If the contract involves digging trenches or other excavations that extend deeper than four feet below the surface, the Contractor shall:
  - i. Promptly, and before the following conditions are disturbed, notify the Owner, in writing, of any:
    - a) Material that the Contractor believes may be material that is hazardous waste, as defined in Section 25117 of the Health and Safety Code, that is required to be removed to a Class I, Class II, or Class III disposal site in accordance with provisions of existing law.
    - b) Subsurface or latent physical conditions at the site differing from those indicated.
    - c) Unknown physical conditions at the site of any unusual nature, different materially from those ordinarily encountered and generally recognized as inherent in work of the character provided for in the contract.
  - b. That the Owner, or Engineer, if there is one, shall promptly investigate the conditions, and if he finds that the conditions do materially so differ, or do involve hazardous waste, and cause a decrease or increase in the Contractor's cost of, or the time required for, performance of any part of the work shall issue a change order under the procedures described herein. If a dispute arises between the Owner and the Contractor whether the conditions materially differ, or involve hazardous waste, or cause a decrease or increase in the Contractor's cost of, or time required for, performance of any part of the work, the Contractor shall not be excused from any scheduled completion date provided for by the Contract but shall proceed with all work to be performed under the Contract. The Contractor shall retain all rights provided herein which pertain to the resolution of disputes and protests between the contracting parties.

1-32 UTILITY RELOCATION

- a. Owner shall assume the responsibility for the timely removal, relocation, or protection of existing main or trunkline utility facilities which may be located on the project site if either Owner, or Engineer, if there is one, fails to identify the utilities in the plans and specifications made a part of the Notice Inviting Bids, and Owner shall compensate Contractor for the costs of locating, repairing damage not due to the failure of the Contractor to exercise reasonable care, and removing or relocating such utility facilities

not indicated in the plans and specifications with reasonable accuracy, and for equipment on the project necessarily idled during such work. If the Contractor while performing the Contract discovers utility facilities not identified by the Owner in the Contract plans or specifications, he shall immediately notify Owner, or Engineer, if there is one, in writing.

- b. Contractor shall not be assessed liquidated damages for delay in completion of the project when such delay was caused by the failure of the public agency or the owner of the utility to provide for removal or relocation of such utility facilities.
- c. Nothing herein shall be deemed to require Owner to indicate the presence of existing service laterals or appurtenances whenever the presence of such utilities on the site of the construction project can be inferred from the presence of other visible facilities, such as buildings, meter and junction boxes, on or adjacent to the site of the construction; provided, however, nothing herein shall relieve Owner, or Engineer, if there is one, from identifying main or trunklines in the plans and specifications.

#### 1-33 TIME OF COMPLETION

The Contractor shall commence work within five (5) calendar days after receipt of Notice to Proceed and shall complete the Contract work within the time limit specified herein:

**Time of Completion: 90 Calendar Days**

- a. Workdays shall be Monday through Fridays except legal holidays and work hours shall be 7:30 a.m. to 4:30 p.m.

#### 1-34 UNFAIR BUSINESS PRACTICES CLAIMS

In entering into this Contract, Contractor offers and agrees to assign to the Owner all rights, title, and interest in and to all causes of action it may have under Section 4 of the Clayton Act (15 U.S.C sec. 15) or under the Cartwright Act (Chapter 2 (commencing with Section 16700) of Part 2 Division 7 of the Business and Professions Code), arising from purchases of goods, services, or materials pursuant to the public works contract or subcontract. This assignment is made and becomes effective at the time the Owner tenders final payment to the Contractor, without further acknowledgment by the parties.

#### 1-35 OWNER'S RIGHT TO TERMINATE, AMEND, OR MODIFY CONTRACT

- a. Contractor shall not be responsible for the cost of repairing or restoring damage to the work, which damage is determined to have been proximately caused by an act of God, more than 5 percent of the contracted amount, provided, that the work damaged is built in accordance with accepted and applicable building standards and the plans and specifications of the awarding authority. Pursuant to Public Contract Code section 7105, "Acts of God" shall include only the following occurrences or conditions and effects: earthquakes more than a magnitude of 3.5 on the Richter Scale and tidal waves.
- b. Owner may make changes in the Contract during construction to bring the

completed improvements into compliance with environmental requirements or standards established by state and federal statutes and regulations enacted after the Contract has been awarded or entered into. Contractor shall be paid for the changes in accordance with the provisions of the Contract governing payment for changes in the work or, if no provisions are set forth in the Contract, payment shall be as agreed to by the parties.

- c. Owner may, by mutual consent of the contracting parties, terminate, amend, or modify the Contract. The compensation payable, if any, for amendments and modifications shall be determined as the parties so agree. The compensation payable, if any, in the event the Contract is so terminated shall be determined as the parties so agree or under applicable statutory provision providing for the termination.
- d. Owner may, at its discretion, terminate the Contract for environmental considerations, whether or not such considerations were foreseen at the time the parties entered the Contract.
- e. If the Contractor should be adjudged a bankrupt, or if he should make a general assignment for the benefit of his creditors, or if a receiver should be appointed on account of his insolvency, or if he should persistently or repeatedly refuse or should fail, except in cases for which extension of time is provided, to supply enough properly skilled work mentor proper materials, or if he should fail to make prompt payment to subcontractors or for material or labor, or persistently disregard laws, ordinances or the instructions of the Owner, or Engineer, if there is one, or otherwise be guilty of a substantial violation of any provision of the Contract, then the Owner may without prejudice to any other right or remedy and after giving the Contractor seven days written notice, terminate the employment of the Contractor and take possession of the premises and of all materials, tools and appliances thereon and finish the work by whatever method he may deem expedient. In such case the Contractor shall not be entitled to receive any further payment until the work is finished. If the unpaid balance of the contract price shall exceed the expense of finishing the work including compensation for additional managerial and administrative services, such excess shall be paid to the Contractor. If such expense shall exceed such unpaid balance, the Contractor shall pay the difference to the Owner. The expense incurred by the Owner as herein provided, and the damage incurred through the Contractor's default, shall be certified by the Engineer, if there is one.

#### 1-36 CONTRACTOR STAGING OF MATERIALS

The Contractor shall be allowed to stage construction materials needed for the project at the immediate job site, providing that such materials do not impose on Public Right of Ways and poses no hazard to the public. Contractor shall plan for delivery of material to the extent possible that has the least impact to the job site. If a product cannot be stored at the job site and will be used within a short period of time, advance arrangements may be made with the Highlands Recreation District. The District does not assume any liability for any material or product stored at or near the job site.

#### 1-37 PARKING OF VEHICLES AND EQUIPMENT

- a. Due to the limited space available at the job site, construction equipment and vehicles cannot be stored on any Public Right of Way. If a unit of construction equipment needs to remain at or near the job site after normal business hours, arrangement must be made in advance with the Highlands Recreation District and San Mateo County. The District assumes no liability for such equipment.
- b. Parking of company and personal vehicles is limited due to space available at the job site. All local and county traffic and parking ordinances must be followed during construction. If other than normal Legal Street parking is needed during business hours, arrangements must be made in advance with San Mateo County.

**CERTIFICATION BY CONTRACTOR**

I am aware of the provisions of Section 3700 of the Labor Code which require every employer to be insured against liability of workers' compensation or to undertake self-insurance in accordance with the provisions of that code, and I will comply with such provisions before commencing the performance of the work of this contract.

CONTRACTOR:

\_\_\_\_\_

BY: \_\_\_\_\_

TITLE: \_\_\_\_\_

CONTRACTOR'S LICENSE NUMBER: \_\_\_\_\_

TELEPHONE NUMBER: \_\_\_\_\_

# CALIFORNIA PUBLIC CONTRACT CODE

## SECTION 20104-20104.6

20104. (a) (1) This article applies to all public works claims of three hundred seventy-five thousand dollars (\$375,000) or less which arise between a contractor and a local agency.

(2) This article shall not apply to any claims resulting from a contract between a contractor and a public agency when the public agency has elected to resolve any disputes pursuant to Article 7.1 (commencing with Section 10240) of Chapter 1 of Part 2.

(b) (1) "Public work" means "public works contract" as defined in Section 1101 but does not include any work or improvement contracted for by the state or the Regents of the University of California.

(2) "Claim" means a separate demand by the contractor for (A) a time extension, (B) payment of money or damages arising from work done by, or on behalf of, the contractor pursuant to the contract for a public work and payment of which is not otherwise expressly provided for or the claimant is not otherwise entitled to, or (C) an amount the payment of which is disputed by the local agency.

(c) The provisions of this article or a summary thereof shall be set forth in the plans or specifications for any work which may give rise to a claim under this article.

(d) This article applies only to contracts entered into on or after January 1, 1991.

20104.2. For any claim subject to this article, the following requirements apply:

(a) The claim shall be in writing and include the documents necessary to substantiate the claim. Claims must be filed on or before the date of final payment. Nothing in this subdivision is intended to extend the time limit or supersede notice requirements otherwise provided by contract for the filing of claims.

(b) (1) For claims of less than fifty thousand dollars (\$50,000), the local agency shall respond in writing to any written claim within 45 days of receipt of the claim, or may request, in writing, within 30 days of receipt of the claim, any additional documentation supporting the claim or relating to defenses to the claim the local agency may have against the claimant.

(2) If additional information is thereafter required, it shall be requested and provided pursuant to this subdivision, upon mutual agreement of the local agency and the claimant.

(3) The local agency's written response to the claim, as further documented, shall be submitted to the claimant within 15 days after receipt of the further documentation or within a period of time no greater than that taken by the claimant in producing the additional information, whichever is greater.

(c) (1) For claims of over fifty thousand dollars (\$50,000) and less than or equal to three hundred seventy-five thousand dollars (\$375,000), the local agency shall respond in writing to all written claims within 60 days of receipt of the claim, or may request, in writing, within 30 days of receipt of the claim, any additional documentation supporting the claim or relating to defenses to the claim the local agency may have against the claimant.

(2) If additional information is thereafter required, it shall be requested and provided pursuant to this subdivision, upon mutual agreement of the local agency and the claimant.

(3) The local agency's written response to the claim, as further documented, shall be submitted to the claimant within 30 days after receipt of the further documentation, or within a period of time no greater than that taken by the claimant in producing the additional information or requested documentation, whichever is greater.

(d) If the claimant disputes the local agency's written response, or the local agency fails to respond within the time prescribed, the claimant may so notify the local agency, in writing, either within 15 days of receipt of the local agency's response or within 15 days of the local agency's failure to respond within the time prescribed, respectively, and demand an informal conference to meet and confer for settlement of the issues in dispute. Upon a demand, the local agency shall schedule a meet and confer conference within 30 days for settlement of the dispute.

(e) Following the meet and confer conference, if the claim or any portion remains in dispute, the claimant may file a claim as provided in Chapter 1 (commencing with Section 900) and Chapter 2 (commencing with Section 910) of Part 3 of Division 3.6 of Title 1 of the Government Code. For purposes of those provisions, the running of the period of time within which a claim must be filed shall be tolled from the time the claimant submits his or her written claim pursuant to subdivision (a) until the time that claim is denied as a result of the meet and confer process, including any period of time utilized by the meet and confer process.

(f) This article does not apply to tort claims and nothing in this article is intended nor shall be construed to change the time periods for filing tort claims or actions specified by Chapter 1 (commencing with Section 900) and Chapter 2 (commencing with Section 910) of Part 3 of Division 3.6 of Title 1 of the Government Code. 20104.4. The following procedures are established for all civil actions filed to resolve claims subject to this article:

(a) Within 60 days, but no earlier than 30 days, following the filing or responsive pleadings, the court shall submit the matter to nonbinding mediation unless waived by mutual stipulation of both parties. The mediation process shall provide for the selection within 15 days by both parties of a disinterested third person as mediator, shall be commenced within 30 days of the submittal, and shall be concluded within 15 days from the commencement of the mediation unless a time requirement is extended upon a good cause showing to the court or by stipulation of both parties. If the parties fail to select a mediator within the 15-day period, any party may petition the court to appoint the mediator.

(b) (1) If the matter remains in dispute, the case shall be submitted to judicial arbitration pursuant to Chapter 2.5 (commencing with Section 1141.10) of Title 3 of Part 3 of the Code of Civil Procedure, notwithstanding Section 1141.11 of that code. The Civil Discovery Act (Title 4 (commencing with Section 2016.010) of Part 4 of the Code of Civil Procedure) shall apply to any proceeding brought under this subdivision consistent with the rules pertaining to judicial arbitration.

(2) Notwithstanding any other provision of law, upon stipulation of the parties, arbitrators appointed for purposes of this article shall be experienced in construction law, and, upon stipulation of the parties, mediators and arbitrators shall be paid necessary and reasonable hourly rates of pay not to exceed their customary rate, and such fees and expenses shall be paid equally by the parties, except in the case of arbitration where the arbitrator, for good



cause, determines a different division. In no event shall these fees or expenses be paid by state or county funds.

(3) In addition to Chapter 2.5 (commencing with Section 1141.10) of Title 3 of Part 3 of the Code of Civil Procedure, any party who after receiving an arbitration award requests a trial de novo but does not obtain a more favorable judgment shall, in addition to payment of costs and fees under that chapter, pay the attorney's fees of the other party arising out of the trial de novo.

(c) The court may, upon request by any party, order any witnesses to participate in the mediation or arbitration process.

20104.6. (a) No local agency shall fail to pay money as to any portion of a claim which is undisputed except as otherwise provided in the contract.

(b) In any suit filed under Section 20104.4, the local agency shall pay interest at the legal rate on any arbitration award or judgment. The interest shall begin to accrue on the date the suit is filed in a court of law.

**BID FORM  
FOR  
Highlands Recreation District Playground and Sports Court Renovation Project**

The undersigned declares that the only persons or parties interested in this Bid as principals are as stated; that the Bid is made without any collusion with other persons, firms, or corporations; that all the Contract Documents as accepted by the Highlands Recreation District and dated April 2022, have been carefully examined; that the undersigned is fully informed in regard to all conditions pertaining to the Work and the place where it is to be done, and from them the undersigned makes this Bid. These prices shall cover all expenses incurred in performing the Work required under the Contract Documents, of which this Bid Form is a part.

If a Notice of Award accompanied by at least four (4) unsigned copies of the Agreement and all other applicable Contract Documents is delivered to the undersigned within ninety calendar days after the actual date of the opening of the Bids, the undersigned will within five (5) working days after the date of receipt of such notification, execute and return all copies of the Agreement and all other applicable Contract Documents to OWNER. The premiums for all Bonds required shall be paid by CONTRACTOR and shall be included in the Contract Price. The undersigned Bidder further agrees that the Bid Security accompanying this Bid shall become the property of OWNER if the Bidder fails to execute the Agreement as stated above.

The undersigned hereby agrees that the Contract Time shall commence five (5) working days following the date specified in the Notice to Proceed and to complete all work contained in these bid documents within 90 calendar days from the date established by the Notice to Proceed in accordance with the terms as stated in the Contract.

The undersigned further agrees to pay OWNER, as liquidated damages, \$200 per day for each calendar day beyond the Contract Completion Date or extension thereof that any of the Work remains incomplete.

The undersigned acknowledges receipt of addenda numbered:

---

(Write all addenda numbers received here)

## Highlands Recreation District Playground and Sports Court Renovation Project

### SITE PREP AND DEMO

1. Remove/Dispose Inner Playground Fence	_____ LS	\$ _____
2. Remove/Dispose Entry Ramp	_____ LS	\$ _____
3. Remove/Dispose Concrete Picnic Tables	_____ LS	\$ _____
4. Remove Basketball Ct. Fence	_____ LS	\$ _____
5. Remove/Dispose Sand Box & Sand	_____ LS	\$ _____

### PLAY AREA DEVELOPMENT

6. Refurbish Fence Along Access Road	_____ LS	\$ _____
7. Relocate Shade Umbrella & Tot Swing	_____ LS	\$ _____
8. (N) Chain Link Fence 4' HT.	_____ LS	\$ _____
9. Relocate/ Repair 2-5 Play structure	_____ LS	\$ _____
10. Repair 5-12 Play Structure	_____ LS	\$ _____
11. Top Off EWF Wood Chips 25 CY	_____ CY	\$ _____
12. Arch Basket Swing and Solo Spinner	_____ LS	\$ _____

### ATHLETIC COURTS

13. Furnish/Install Basketball Standard	_____ LS	\$ _____
14. Repair Cracks & Slurry Seal Courts	_____ LS	\$ _____

### PARK IMPROVEMENTS

15. Furnish/Install Picnic Area	_____ LS	\$ _____
16. Furnish/Install Jug filler Fountain	_____ LS	\$ _____
17. Provide/Install Sand Play Area	_____ LS	\$ _____
18. Furnish/Install Entry Ramp & Railings	_____ LS	\$ _____
19. Furnish/Install Curved Trex Benches (2)	_____ EA	\$ _____

**BASE BID TOTAL**      \$ \_\_\_\_\_

### ADD ALTERNATE ITEMS

ADD ALT 1. Furnish/Install Basketball Court Lighting	_____ LS	\$ _____
ADD ALT 2. Furnish/Install Rock Craft Ledge	_____ LS	\$ _____
ADD ALT 3. Furnish/Install Gametime Vista Tree top 2	_____ LS	\$ _____
ADD ALT 4. Furnish/Install Playcraft Play Panels	_____ LS	\$ _____
ADD ALT 5. Relocate Ball back Board	_____ LS	\$ _____

ADD ALT 6. Re Grade sports court to mitigate slope	_____ LS	\$ _____
ADD ALT 7. Color coat and Restripe Court	_____ LS	\$ _____
ADD ALT 8. Furnish/Install STD Drinking Fountain in play area	_____ LS	\$ _____

In accordance with the above understanding, the undersigned proposes to perform the Work, furnish all materials and complete the Work in its entirety, in the manner and under the conditions required in the contract documents for the Total Base Bid Price of:

---

(Amount in words)

\$ \_\_\_\_\_.

(Amount in numbers)

The undersigned agrees that extra work, if any, will be performed in accordance with Article 1-11 of the General Conditions of the Contract and will be paid for in accordance with Article 1-18 of the General Conditions of the Contract.

Amounts shall be shown in both words and figures, where indicated. In case of discrepancy, the amount shown in words will govern.

The above prices shall include all labor, materials, bailing, shoring, removal, overhead, profit, taxes, insurance and incidentals required to complete the Work. The names and addresses of all persons and parties interested in the foregoing Bid as principals are as follows:

(Give full name of corporation, or partnership, or Limited Liability Company, or Individual, or Joint Venture.)

---



---

The undersigned hereby certifies that they can furnish labor that can work in harmony with all other elements of labor employed or to be employed on the work.

The undersigned hereby certifies under the penalties of perjury that this bid is in all respects bona fide, fair, and made without collusion or fraud with any other person. As used in this section, the word "person" shall mean any natural person, joint venture, partnership, corporation, or other business or legal entity.

---

Social Security Number or Federal ID

---

Signature of Individual or Corporate Name

---

Contractor's State License Number

By: \_\_\_\_\_  
Corporate Officer (if applicable)

Notice of acceptance should be mailed, faxed, emailed, or delivered to the following:

\_\_\_\_\_  
(Name)

By: \_\_\_\_\_  
(Title)

\_\_\_\_\_  
(Business Address)

\_\_\_\_\_  
(City and State)

\_\_\_\_\_  
(Phone Number)

\_\_\_\_\_  
(Email address)

Date: \_\_\_\_\_

**Highlands Recreation District Playground and Sports Court Renovation Project**  
**Bid Items Detail**

**SITE PREP AND DEMO**

- 1) Remove and dispose of entire inner fence including posts, chain link materials and top boards. Remove any protruding concrete above subgrade. Estimated length 118 Feet. Demo Plan Note A
- 2) Remove and dispose of concrete entry ramp, wood railings and base material down to match elevation of EWF sub grade. Demo Plan Note J
- 3) Remove and dispose of concrete picnic tables 2 each and underlying concrete slab. Minimize Contamination of EWF. Demo Plan Note C
- 4) Remove and dispose of fence between play area and basketball court. Posts shall remain and be cut off 6" above asphalt surface. Minimize Contamination of EWF. Demo Plan Note H
- 5) Remove and dispose of sand and sand box boards. Salvage 3 cubic yards for new sand play box. Demo Plan Note B

**PLAY AREA DEVELOPMENT**

- 6) Detail #6 Furnish and install redwood 2X12 and 2X8 S4S along entire fence. Attached with 3 ½" #8 screw 2 per board per post. Pilot drill all holes w/Correct pilot bit. Furnish and install 2 each. 4X4 P.T. posts at locations on plan. Footings shall be 18" diameter by 36". Estimated Length 125 Feet. Pilot Drill for all screws
- 7) Remove & Salvage intact existing shade umbrella. Relocate to new sand play area and center in sand box. Location to be approved by General Manager. Footing shall be 24" diameter by 48" deep with rebar cage. Tot swing shall be removed intact and relocated per plan. Footing per plan detail. Demo Plan Notes E & G
- 8) Detail # 8 A new chain link fence between play area and basketball court, shall be 48" high above asphalt level. Use 2 3/8" end and gate posts. Line posts shall be 1 7/8 with 1 3/8" top and bottom rails. Chain link 9GA black vinyl coated (11 GA. wire). Place posts to coordinate with shade and retainer board posts. Footings 12" Dia X 36" Deep.
- 9) Landscape Structure (LSI) Play Shaper shall be removed intact and relocated per plan. New parts list items shall be replaced in process. Contact 707.538.3800 Rebecca Whitten at Ross recreation for parts and Quotation #00035147 [rebeccaw@rossrec.com](mailto:rebeccaw@rossrec.com). Salvage EWF and stock pile for Later use. Demo Plan Note D
- 10) Repair LS 5-12 play structure with parts as noted from Ross recreation Quote# 00035147, or equal. Contact Rebecca Whitten at 707.538.3800 [rebeccaw@rossrec.com](mailto:rebeccaw@rossrec.com) Demo Plan Note K
- 11) At completion of play area site work, Furnish and install engineered wood fiber 25 cubic yards Contact Supplier Jetmulch Bridget Tracy at [Quotes@Jetmulch.com](mailto:Quotes@Jetmulch.com) or equal.

- 12) Furnish and install game time single Arch Swing #5056 and Solo Spinner #6246, or equal. Contact Leo Seavey at [MRC@lseavey@mrcrec.com](mailto:MRC@lseavey@mrcrec.com) Locate Playground equipment per plan

### **ATHLETIC COURTS**

- 13) Detail # 13 Furnish and install new basketball standard at location per plan. Footing shall be 24" by 48" Deep. Product: Bison Ultimate: adjustable steel system sku #20020498 From Bsnsports.com, or equal.
- 14) Repair cracks and slurry seal entire asphalt court surface. Restripe courts with white paint 2" wide and include 2 half court basketball courts with 3-point lines and one pickleball court. Contact Sean Kunz at American Asphalt [Sean@americanasphalt.com](mailto:Sean@americanasphalt.com) (510) 723-0280 for specifications and pricing, or equal.

### **PARK IMPROVEMENTS**

- 15) Detail #16 Picnic area shall include:
- A. Stabilized, d.g. surface 3" deep over 4" CL 2 base rock Lyngso Garden Materials San Carlos (650)364-1730 or equal.
  - B. Gametime Cantilever 24'X14'X10' Height Shade Canopy #QR1396, or equal. Contact Leo Seavey @ [lseavey@mrcrec.com](mailto:lseavey@mrcrec.com)
  - C. New pedestal picnic tables, including Squaw 46" pedestal tables (2 each), Tree Top Products #1TH1007, or equal; and ADA table (1 each). Color: green tops and seats, black frame. Punched steel tops. (Optional supplier contact [treetopproducts.com](http://treetopproducts.com) (888)438-2535)
- 16) Detail #17 Jug filler shall replace existing drinking fountain at entrance to tennis courts, utilize existing water supply, concrete slab for attachment and reconnect existing drain. Make necessary adjustments for installation. Demo Plan Note M  
Product: EL KMP #LK 4420EVG, or equal  
Color: Ever Green  
Contact Restroom direct (704) 937-2673
- 17) Detail #18 Sand Play enclosure shall be 9'X18' constructed with combination of redwood logs at 12-16" Diameter by 4'-6' length and Sonoma Field Stone boulders 18"-24" diameter, or equal. Size and location per plan. Provide 12" deep OLY2 playground sand, or equal, to top off 3 cubic yards of sand recycled from sand box. Use Mirafi 140 filter fabric underlayment for sand, or equal. Lynso Garden Materials (650)364-1730. Redwood Logs Community Playgrounds (415)892-8100.
- 18) Detail #19 Provide 48" wide ADA Ramp and Galvanized Railings as entry to play area from Basketball Court. Ramp shall not exceed 1:12 scope (8.33%). Ramp deck shall be 4" concrete with #3 rebar 15" o.c. each way railings shall be 36" height, posts 6' o.c., 1 1/2" sched. 40, Rails 1 1/4" sched. 40, round ends shall extend 12". Concrete pad 5'X5'X4" Shall be installed at end of ramp and transition flush into picnic area. Submit drawing of proposed railing for approval
- 19) Curved Trex Bench shall be Community Products #156C, or equal. Contact Mary Arias at (415)892-8100 Color: Tiki Torch footings shall be 12" Dia. X 30" Deep.

**NOTES:**

- Confirm all play equipment locations conform to ASTM 1487-21 and Consumer Product Safety Commission NO. 325 Playground Handbook Specifications for use zones.
- Salvage all engineered wood fiber prior to demolition and construction and stockpile for use at completion of new playground equipment installations.
- Locations of new and relocated play equipment and site furnishings shall be marked with paint and approved by General Manager.



**Highlands Recreation District Playground and Sports Court Renovation Project  
Additional Alternate Items Detail**

ADD ALT 1. Outdoor Basketball Lighting Plans: Furnish and install sports lighting systems. Per Plans and Specifications. The District has submitted plans for approval and paid necessary permit fees with the County of San Mateo.

ADD ALT 2. Furnish and install Rock Craft "Ledge" as Indicted on plan as EQUIP. T.B.D  
Supplier: Crozier Enterprises LTD Ent (416)369-0515 [Tuyenkracht@crozier.ca](mailto:Tuyenkracht@crozier.ca) , or equal.  
Color: Sandstone

ADD ALT 3. Furnish and install Gametime Vista Tree Top 2 from MRC Recreation, or equal.  
[Lseavey@mrcrec.com](mailto:Lseavey@mrcrec.com)  
Locate as indicated on plan as "Equip T.B.D."

ADD ALT 4. Furnish and install Play Craft Activity Panels 2 Each, or equal, at plan location. Orientation to be approved by park staff. Locate as indicated on plan as "Equip T.B.D"  
Color: Tan/Green Detail ADD ALT 4  
Contact: Misha Holiman [Misha@parkplanet.com](mailto:Misha@parkplanet.com)

ADD ALT 5. Remove intact and relocate Wood Ball Back Board per plan. Cut (E) wood posts flush with paved surface to remove and remove Backboard intact. Relocate using new Pressure treated 4X6 Posts Bolted to each side and Center of Backboard. Footings shall be 18" Dia X 48" Deep. New center post shall be 48" above finish grade and 48" into in ground footing. Bolt new posts to (E) side post, bolt shall be ½" diameter galvanized machine bolts, 4 per posts 24" o.c.

ADD ALT 6. Provide asphalt overlay to existing basketball court. Add 6" of asphalt paving at Play Area edge and diminish thickness to opposite side of existing court to mitigate existing slope. Contact Sean Kunz at American Asphalt for Specifications and Quotation to complete this phase or equal.  
[Sean@americanasphalt.com](mailto:Sean@americanasphalt.com) (510) 723-0280

ADD ALT 7. Color coat and restripe courts – add color to both half courts for 3-point areas and keys on both courts.  
Product: Sport Flex Standard, or equal.  
Contact Flexground, Sandi Walsh (916)474-5431 [swalsh@flexground..com](mailto:swalsh@flexground..com)

ADD ALT 8. Furnish and install New Standard Drinking Fountain in play area. Reuse water supply foundation and any (E) Drain. Supplier: Elkay Model LK4420EVG, or equal  
Contact Restrooms Direct (704) 937-2673  
Color: Ever Green

**LIST OF SUBCONTRACTORS**

**Highlands Recreation District Playground and Sports Court Renovation Project**

In Compliance with the provisions of Sections 4100 to 4113 of the Public Contract Code of the State of California, and any amendments thereof, each Bidder shall set forth below the name, location of place of business, California contractor license number, DIR Registration number and description of work to be performed of each subcontractor who will perform work or labor or render service to the Contractor on or about the construction of the Work or improvement to be performed under these specifications and the portion of the Work which will be done by each subcontractor in an amount more than one-half of 1 percent of the bidder's Bid.

If the Contractor fails to specify a subcontractor for any portion of the Work to be performed under the contract more than one-half of 1 percent, he shall be deemed to have agreed to perform such portion himself, and he shall not be permitted to subcontract that portion of the Work except under the conditions hereinafter set forth.

Subletting or subcontracting of any portion of the Work as to which no subcontractor was designated in the original Bid shall only be permitted in cases of public emergency or necessity or as necessary pursuant to a Change Order.

1. Name of Subcontractor: \_\_\_\_\_ License No. \_\_\_\_\_

Address: \_\_\_\_\_

DIR Registration No. \_\_\_\_\_ Description of Work to be Performed

(Type & Trade) \_\_\_\_\_

2. Name of Subcontractor: \_\_\_\_\_ License No. \_\_\_\_\_

Address: \_\_\_\_\_

DIR Registration No. \_\_\_\_\_ Description of Work to be Performed

(Type & Trade) \_\_\_\_\_

3. Name of Subcontractor: \_\_\_\_\_ License No. \_\_\_\_\_

Address: \_\_\_\_\_

DIR Registration No. \_\_\_\_\_ Description of Work to be Performed

(Type & Trade) \_\_\_\_\_

4. Name of Subcontractor: \_\_\_\_\_ License No. \_\_\_\_\_

Address: \_\_\_\_\_

DIR Registration No. \_\_\_\_\_ Description of Work to be Performed

(Type & Trade) \_\_\_\_\_

5. Name of Subcontractor: \_\_\_\_\_ License No. \_\_\_\_\_

Address: \_\_\_\_\_

DIR Registration No. \_\_\_\_\_ Description of Work to be Performed

(Type & Trade) \_\_\_\_\_

6. Name of Subcontractor: \_\_\_\_\_ License No. \_\_\_\_\_

Address: \_\_\_\_\_

DIR Registration No. \_\_\_\_\_ Description of Work to be Performed

(Type & Trade) \_\_\_\_\_

FIRM NAME: \_\_\_\_\_

BY: \_\_\_\_\_

TITLE: \_\_\_\_\_

**BIDDER'S RESPONSIBILITY STATEMENT  
FOR  
Highlands Recreation District Playground and Sports Court Renovation Project**

1. SCOPE OF THIS STATEMENT

To allow the Highlands Recreation District to decide of the Bidder's responsibility, the Bidder shall provide the following information as a part of its Bid. The District shall consider the information contained in this Statement as personal and proprietary to the Bidder, and the District shall use the information for the sole purpose of determining the Bidder's responsibility. Unless otherwise compelled by a court order, the District shall not consider this Statement to be a public record; provided, however, that the Bidder shall indemnify, defend, and hold the District harmless from any claim or litigation related to the District's classification of this document as exempt from disclosure under the Public Records Act. If additional pages are required to respond to any of the questions set forth in this Statement, the Bidder shall describe and list the additional pages in Section 8, below.

2. EXPERIENCE

- a. How many years has the Bidder been performing work as a contractor under the present business name for installation of playground equipment and other park amenities?  
  
\_\_\_\_\_ years.
- b. Prospective bidders shall demonstrate a minimum of 3-years' experience in constructing projects of a similar size and nature for installation of playground equipment.
- c. If any of the experience listed in this document refers to work performed under a different name, list the different business names, and describe the relationship to the present business name on a separate page (list the additional pages in Section 8 below).

3. COMPLETED WORK

Provide the requested information set forth below for at least two (2) most recent projects of similar size and scope completed during the past three (3) years.

- a. Project Name: \_\_\_\_\_  
  
Project Description: \_\_\_\_\_  
  
\_\_\_\_\_
- Contract Amount: \_\_\_\_\_
- Date Completed: \_\_\_\_\_
- Contact Person: \_\_\_\_\_

Contact Person's Phone: \_\_\_\_\_

b. Project Name: \_\_\_\_\_

Project Description: \_\_\_\_\_

\_\_\_\_\_

Contract Amount: \_\_\_\_\_

Date Completed: \_\_\_\_\_

Contact Person: \_\_\_\_\_

Contact Person's Phone: \_\_\_\_\_

c. Project Name: \_\_\_\_\_

Project Description: \_\_\_\_\_

\_\_\_\_\_

Contract Amount: \_\_\_\_\_

Date Completed: \_\_\_\_\_

Contact Person: \_\_\_\_\_

Contact Person's Phone: \_\_\_\_\_

#### 4. CLAIMS HISTORY

a. Has any claim (whether mediated, arbitrated, or litigated) been made against your company in the past five years? \_\_\_\_\_

b. Has your company made any claim (whether mediated, arbitrated, or litigated) against any Public Agency or claim in the past five years? \_\_\_\_\_

c. If you answered "yes" to subsections 4.a. or 4.b. above, describe the claim(s) using the format below: (use additional sheets if necessary).

Project Name: \_\_\_\_\_

Claim Amount: \_\_\_\_\_

Other Party Contact: \_\_\_\_\_

Name and Phone: \_\_\_\_\_

Describe the claim(s) on a separate sheet (see Section 7, below).

5. CONTRACT TERMINATION

Has your company ever been terminated by a public agency or client, or rejected from bidding on a public works project in the last five- (5) years? \_\_\_\_\_. If yes, provide an explanation below:

Project Name: \_\_\_\_\_

City/Client Contact  
Name and Phone: \_\_\_\_\_

Date of Termination/Rejection: \_\_\_\_\_

Explanation: \_\_\_\_\_

\_\_\_\_\_  
\_\_\_\_\_

If more than one (1), describe on additional sheet (see Section 7 below).

6. COMPLETION BY SURETY

Has your company every failed to satisfactorily complete a construction contract, or has a surety ever completed any portion of a construction contract of your company within the last five (5) years? \_\_\_\_\_. If yes, provide an explanation below:

Project Name: \_\_\_\_\_

Surety Contact  
Name and Phone: \_\_\_\_\_

Date of Surety Took Over: \_\_\_\_\_

Explanation: \_\_\_\_\_

\_\_\_\_\_  
\_\_\_\_\_

If more than one (1), describe on additional sheet (see Section 7, below).

7. ADDITIONAL PAGES

The Bidder declares that the pages listed in this Subsection were added and included with these Bid Documents to accurately respond to the Bidding Requirements.

\_\_\_\_\_ (List Pages)

8. PENALTY OF PERJURY

Bidder hereby declares and certifies under penalty of perjury that the information contained herein is true, correct, and complete.

IN WITNESS WHEREOF, the undersigned represent and warrant that they have the right, power, legal capacity and authority to sign this document on behalf of the Bidder, and have caused this document to be executed by setting hereto their names, titles, and signatures.

BIDDER:

\_\_\_\_\_  
Signature(s)

DATE: \_\_\_\_\_

\_\_\_\_\_  
(Name and Title of Signatories)

\_\_\_\_\_  
(Legal Name of Bidder)

\_\_\_\_\_  
(Address)

\_\_\_\_\_  
(Phone Number)

**“NONCOLLUSION AFFIDAVIT”**  
**TO BE EXECUTED BY BIDDER AND SUBMITTED WITH BID**  
**FOR**  
**Highlands Recreation District Playground and Sports Court Renovation Project**

State of California  
County of San Mateo

\_\_\_\_\_, being first duly sworn, deposes and says under penalty of perjury under the laws of the State of California, that he or she has the right, power, legal capacity, and authority to execute this Affidavit, as \_\_\_\_\_ of the party making the foregoing Bid, that the Bid is not made in the interest of, or on behalf of, any undisclosed person, partnership, company, association, organization, or corporation; that the Bid is genuine and not collusive or sham; that the Bidder has not directly or indirectly induced or solicited any other bidder to put in a false or sham bid, and has not directly or indirectly colluded, conspired, connived, or agreed with any bidder or anyone else to put in a sham bid, or that anyone shall refrain from bidding; that the Bidder has not in any manner, directly or indirectly, sought by agreement, communication, or conference with anyone to fix the bid price of the Bidder or any other bidder, or to fix any overhead, profit, or cost element of the bid price, or of that of any other bidder, or to secure any advantage against the public body awarding the contract of anyone interested in the proposed contract; that all statements contained in the Bid are true; and, further, that the Bidder has not, directly or indirectly, submitted his or her bid price or any breakdown thereof, or the contents thereof, or divulged information or data relative thereto, or paid, and will not pay, any fee to any corporation, partnership, company association, organization, bid depository, or to any member or agent thereof to effectuate a collusive or sham bid.”

IN WITNESS WHEREOF, the undersigned represent and, warrant that they have the right, power, legal capacity, and authority to sign this document on behalf of the Bidder, and have caused this document to be executed by setting thereto their names, titles, and signatures at \_\_\_\_\_, County, in the State of \_\_\_\_\_.

BIDDER: \_\_\_\_\_  
(Signature) (Date)

(Name and Title of Signatories)

\_\_\_\_\_  
(Legal Name of Bidder)

\_\_\_\_\_  
(Address)  
\_\_\_\_\_



**BID GUARANTEE  
FOR  
Highlands Recreation District Playground and Sports Court Renovation Project**

Attached hereto and made a part hereof is United States Currency, Cashier's Check, Certified Check or Surety Bond No. \_\_\_\_\_ in the amount of \$ \_\_\_\_\_ which is not less than ten percent (10%) of the total amount of the total bid, as a guaranty that the Bidder will enter into a Contract in the form bound with these Specifications within five (5) days after the notice of award of the Contract by the Owner (hereinafter "Security"). Surety shall be an admitted carrier in the State of California.

The undersigned hereby agrees that, in case his Bid is accepted, he/she will within five (5) working days after notice thereof, execute a Contract with the Owner in the form hereto attached and shall furnish a bond in the sum of the Contract price to secure the payment of all labor and material bills, and a bond in the sum of the Contract price to secure the faithful performance of the Contract according to the terms and provisions therein; and in case of failure to execute the Contract and furnish the bonds within said period or such extension thereof as may be allowed by resolution duly passed and adopted, it is expressly agreed that the Highlands Recreation District may award the Contract to the second lowest bidder and the amount of Bidder's Security shall be applied by the Highlands Recreation District to the difference between Bidder's Bid and the second lowest Bid, and the surplus, if any, shall be returned to Bidder if cash or a check is used, or to the surety on Bidder's bond if a bond is used.

It is understood by the undersigned that the quantities of material of work specified in the "Notice Inviting Bids" are estimated and are given only for the purpose of comparing bids and that the prices quoted are not conditioned upon the accuracy or approximate accuracy of the estimate.

It is understood that the Owner may award a Contract as the interests of the Owner may dictate.

Attached hereto and made a part of this Bid is a Bidder's Responsibility Statement, and a List of Subcontractors as required by the provisions of Sections 4100 to 4113 of the Public Contract Code of the State of California.

CONTRACTOR: \_\_\_\_\_

BY: \_\_\_\_\_

TITLE: \_\_\_\_\_

ADDRESS: \_\_\_\_\_

\_\_\_\_\_

CONTRACTOR'S LICENSE NUMBER: \_\_\_\_\_

TELEPHONE NUMBER: \_\_\_\_\_

**SUMMARY OF WORK  
FOR  
Highland Recreation District Playground and Sports Court Renovation Project**

1. RELATED DOCUMENTS

Drawings and all Division Specification Sections contained within these documents apply to this Section.

2. PROJECT DESCRIPTION

- a. The work to be performed under this Contract shall consist of furnishing all tools, equipment, materials, supplies, and manufactured articles and for furnishing all transportation and services, including fuel, power, water, and essential communications, and for the performance of all labor, work, or other operations required for the fulfillment of the Contract in strict accordance with the Contract Documents. The work shall be complete, and all complete and proper construction of the Work in good faith shall be performed, furnished, and installed by the Contractor, at no increase in cost to the Owner. The Contractor shall also be responsible for construction coordination with other construction activities within the Highlands Recreation District.
- b. The following description is intended only as an outline of Work to be accomplished and is not intended to be a definitive scope of Work. The Scope of Work is defined by the complete set of Contract Documents.
- c. The Project consists of providing shop drawings and data, mobilization of equipment to the site, installation of temporary fencing to secure the work area and direct the public to other areas of the park, removal and off haul and disposal of existing structures, removal and storage of existing engineered wood fiber, reinstallation of existing and new engineered wood fiber, fine grading of the playground under the engineered wood fiber to restore grades to conditions that existed prior to contractor's start of work, reinstalling of drainage fabric and drain rock where applicable, repairs of existing equipment and structures where applicable, installation of playground and sports court equipment, lighting, shade structures and other park amenities, resurfacing of sports court, touch-up painting, final clean-up, removal of temporary fencing.
- d. Project completion shall be defined as all materials being completely and permanently installed in accordance with the contract documents, all work being fully completed including completion of punch list items, and the site being broom clean.

3. WORK SEQUENCE

The Work of this Contract shall be conducted in accordance with the General Contractor's approved Project Schedule which shall include all items of work.

4. OWNER SUPPLIED ITEMS

Prior to the start of any work the Contractor and Owner shall inspect the Owner supplied Components, such as existing play structures and equipment that are planned to be removed and reinstalled in new location. Any damaged components, beyond repair by touch-up painting by contractor, shall be replaced by the Owner and a non-monetary time extension shall be granted to the contractor until the replacement components have been delivered to the Owner. Contractor shall not be entitled to any additional monetary compensation because of the time extension. Once the Contractor takes position of the components, the contractor shall be responsible for any damage that may occur to the components which shall be repaired or replaced as approved by the Owner, at the contractor's expense.

5. CONTRACTOR USE OF PREMISES

- a. During the construction period the contractor shall have full use of the premises identified as the contractor's area of work for construction operation, storage, and stockpiling.
- b. The Contractor shall provide, erect, and maintain all necessary scaffolding, fencing, barricades, and other safety and security devices for the protection of the work, workers, and safety of the public. All work areas shall be cleaned-up daily, or more frequently, if necessary, to prevent accidents and unsightliness to the greatest extent practical. Any component provided by the Owner or any other material that may be stolen from the project site prior to Project completion shall be replaced by the contractor at his sole expense.

6. WARRANTY

Notwithstanding the manufacturer's warranty terms and conditions, the minimum labor warranty for negligent assembly shall be 2 years from the date of contract completion and the Contractor shall be responsible to repair and/or replace any component that may be damaged because of contractor's negligent assembly as determined by the Owner, at no charge to the Owner.

**TECHNICAL SPECIFICATIONS  
FOR  
Highlands Recreation District Playground and Sports Court Renovation Project**

1. RELATED DOCUMENTS AND GENERAL

a. Drawings and all Division Specification Sections contained within these documents apply to this Section.

- 1) Highlands Existing Conditions – Demolition Plan
- 2) Highlands Proposed Plan
- 3) Bid Item Details Sheet
- 4) Toddler Swing Specs
- 5) Playshaper Specs
- 6) Arch Swing
- 7) Solo Spinner
- 8) Shade Structure
- 9) Basketball Court Lighting Plan Check Set
- 10) General Electrical Requirements
- 11) Rock Craft Ledge
- 12) Vistatree Top

b. Contractor shall call Underground Service Alert prior to excavating for any post holes.

2. SUBMITTALS

Provide submittals for all products and items of work contained herein. Submittals shall include product information and manufacturer's recommended installation guide which shall include application rates, installation procedures, mix design and all other information necessary to indicate compliance with the contract documents. Delivery tags for concrete shall include indication that the mix being delivered is the same as was approved during submittal review.

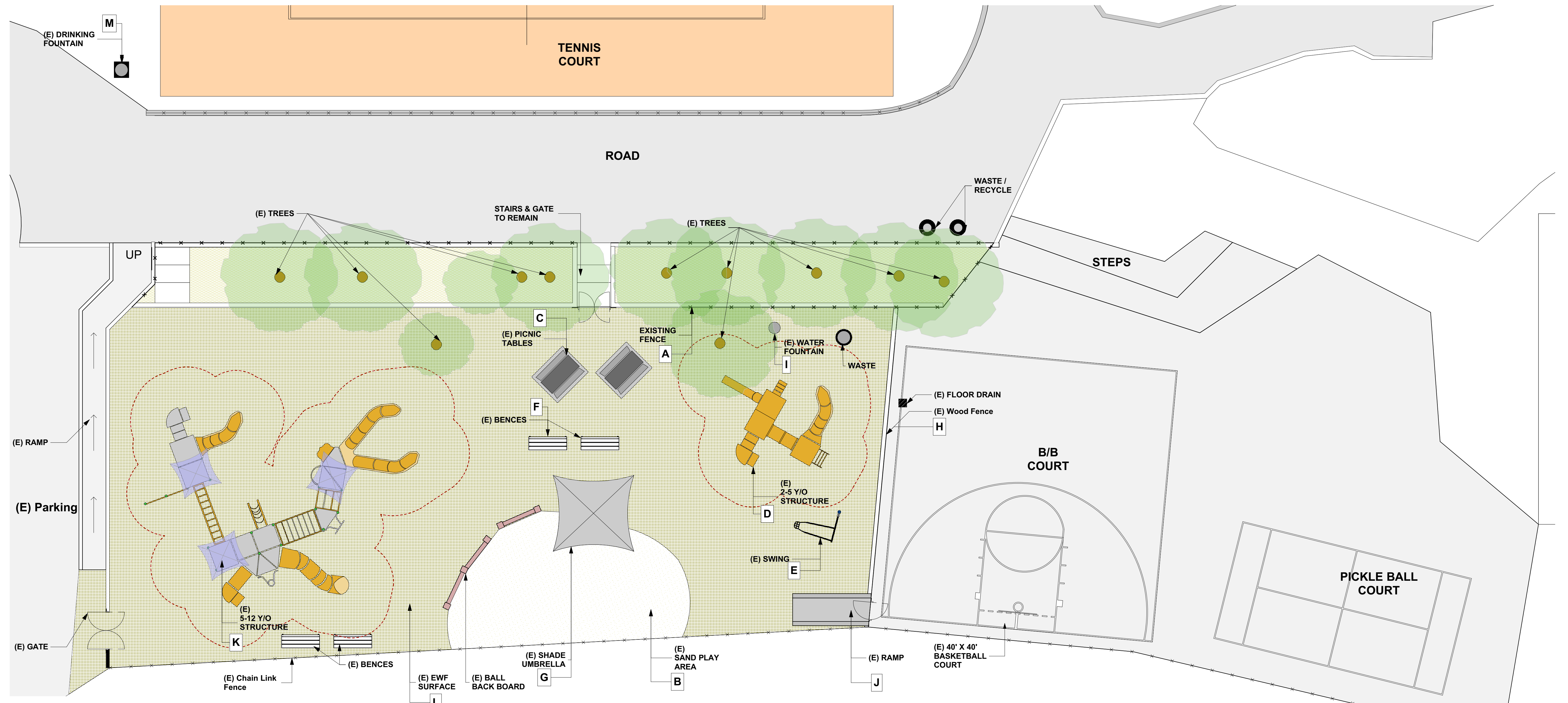

**HIGHLANDS PARK DEMOLITION PLAN**

- A** - Remove / Dispose existing interior playground fence. Center stairs, fence enclosure and gate to remain.
- B** - Remove sand and any borders and enclosures. Salvage 3 cubic yards for reuse and dispose of remainder.
- C** - Remove / Dispose of concrete picnic tables 2 each and concrete bases.
- D** - Remove LSI Play Shaper Play Structure and salvage for relocation & re-installation.
- E** - Remove LSI Tot Swing and salvage for relocation & re-installation.
- F** - Save Benches for relocation.
- G** - Remove / Salvage Shade Umbrella for relocation.
- H** - Remove / Dispose the divider fence between play area and basketball court. Wood support posts to remain in place. Cut so 8" remain above the asphalt court paving.
- I** - Remove / Dispose of existing water fountain. Water supply pipe to be protected and remain for use with new fountain.
- J** - Remove / Dispose of access ramp and base material to play area sub-grade level.
- K** - Play Structure to remain in place and be protected.
- L** - Remove EWF in work areas and stockpile for reuse.
- M** - Remove (E) drinking fountain. Protect water supply for new Jug Filler Fountain.

**EXISTING CONDITIONS / DEMOLITION PLAN**



**Highlands Recreation Center, Lexington Avenue  
SAN MATEO , CA.**

SCALE: 1/8" = 1'-0"  
February 26 2022



ROCK CRAFT LEDGE #ADD ALT 2



VISTA TREE TOP #ADD ALT 3



SINGLE TOT SWING #7



SOLO SPINNER #12

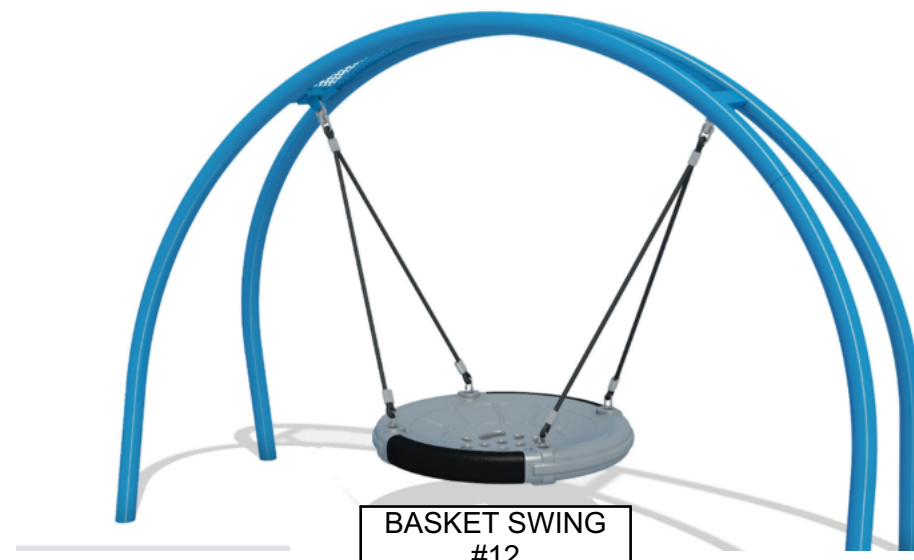

BASKET SWING #12

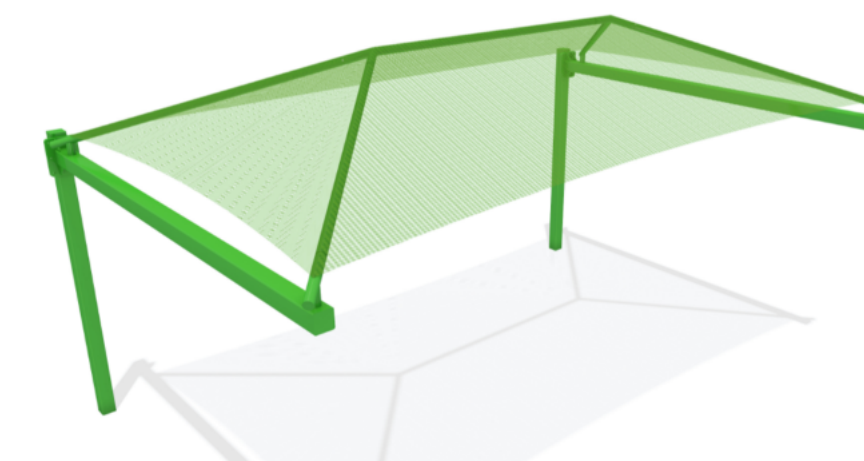

SHADE CANOPY #12



BASKETBALL STANDARD #13



JUG FILLER #17



DRINKING FOUNTAIN #ADD ALT 1

**PLAY AREA DEVELOPMENT**

- 6. Refurbish Fence Along Access Road
- 7. Relocate Shade Umbrella & Tot Swing
- 8. (N) Chain Link Fence 4' HT.
- 9. Relocate/ Repair 2-5 Play structure
- 10. Repair 5-12 Play Structure
- 11. Top Off EWF Wood Chips 25 CY
- 12. Arch Basket Swing and Solo Spinner

**ATHLETIC COURTS**

- 13. Furnish/Install Basketball Standard
- 14. Repair Cracks & Slurry Seal Courts
- 15. Restripe Courts/White Paint

**PARK IMPROVEMENTS**

- 16. Furnish/Install Picnic Area
- 17. Furnish/Install Jug filler Fountain
- 18. Provide/Install Sand Play Area
- 19. Furnish/Install Entry Ramp & Railings
- 20. Furnish/Install Curved Trex Benches (2)

**ADD ALTERNATE ITEMS**

- ADD ALT 1. Furnish/Install STD Drinking Fountain in play area
- ADD ALT 2. Furnish/Install Rock Craft Ledge
- ADD ALT 3. Furnish/Install Gametime Vista Tree top 2
- ADD ALT 4. Furnish/Install Playcraft play Panels
- ADD ALT 5. Relocate Ball back Board
- ADD ALT 6. Re Grade sports court to mitigate slope
- ADD ALT 7. Color coat and Restripe Courts

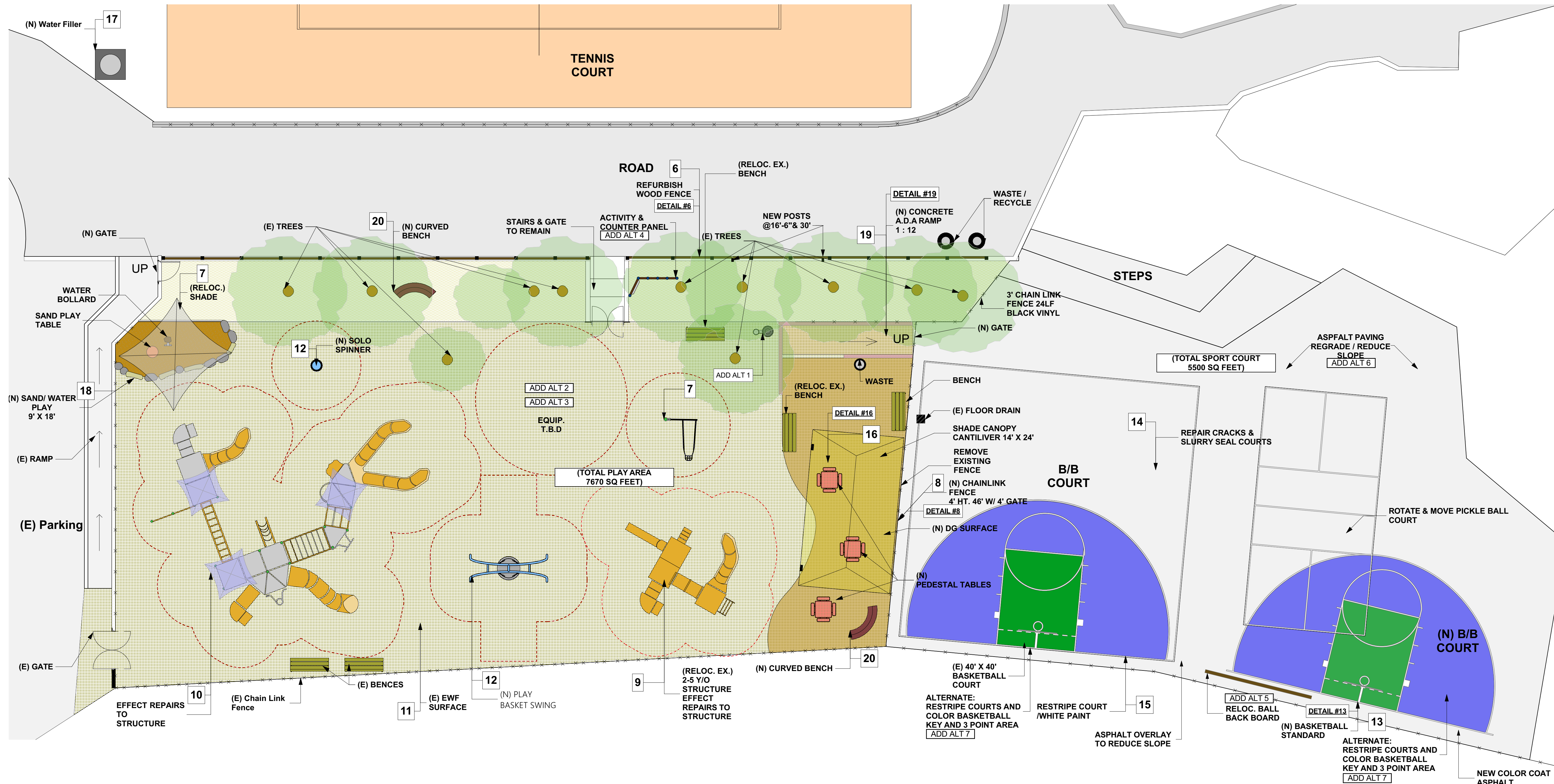

**PROPOSED PLAN**



**Highlands Recreation Center, Lexington Avenue  
SAN MATEO , CA.**

SCALE: 1/8"=1'-0"  
February 28 2022

**DETAIL #6**

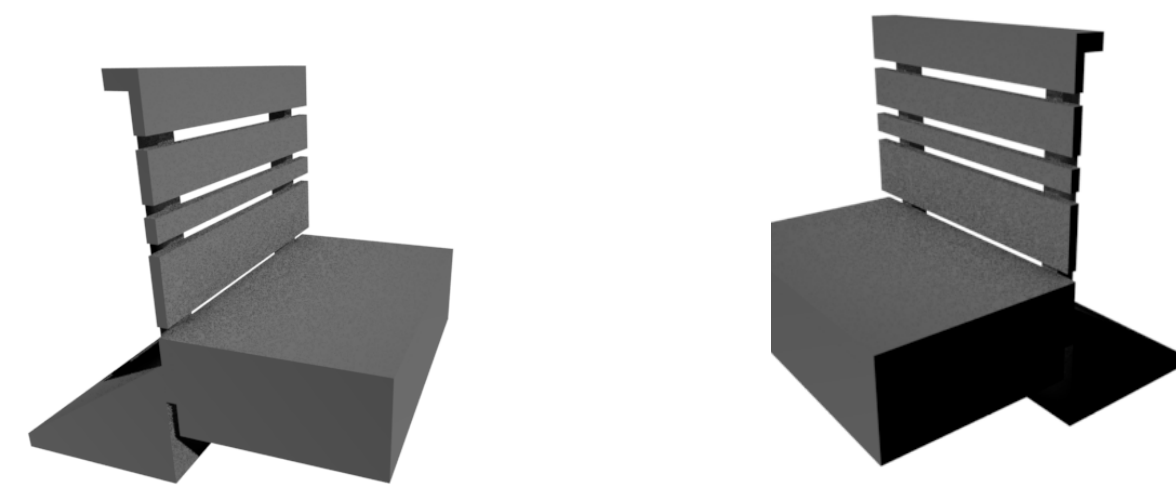

3D VISUAL



ACTUAL PHOTO WITH EDIT

**B) HIGHLANDS PARK  
ADDITIONAL FENCE POSTS**

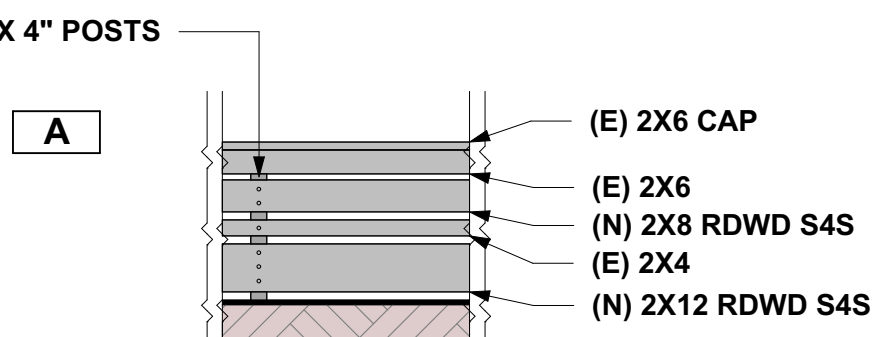
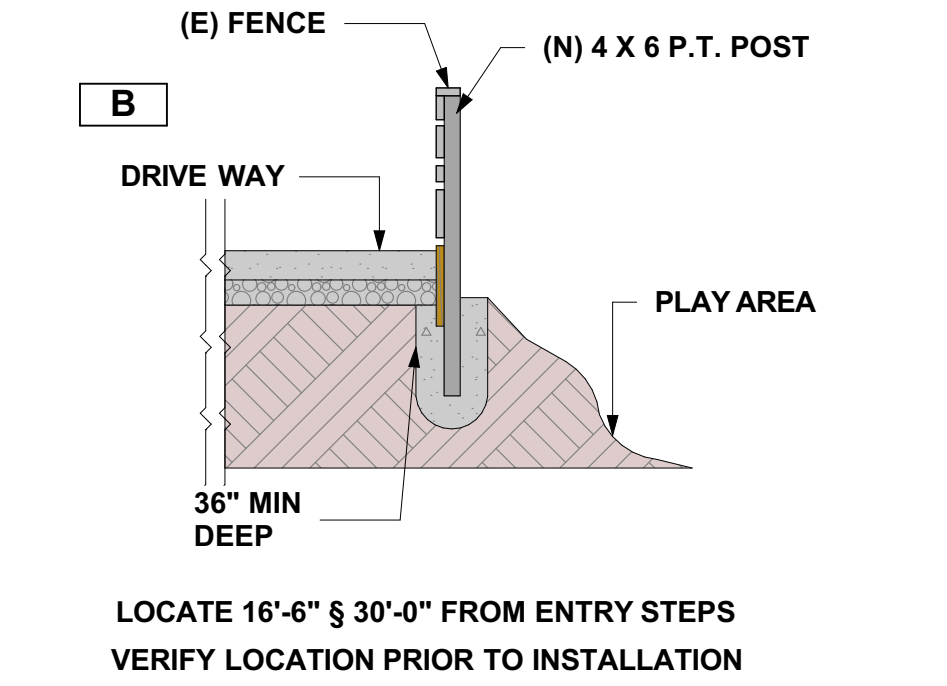

EST. 153 LF OF EACH REDWOOD BOARD SIZE  
ATTACH W/3.5" X #10 DECKMATE CREWS (HM  
DEPOT)  
PILOT DRILL ALL HOLES THRU  
REDWOOD

**A) HIGHLANDS PARK  
FENCE BOARD ADDITIONS**

SECTION AND FRONT ELEVATION

**DETAIL #19**

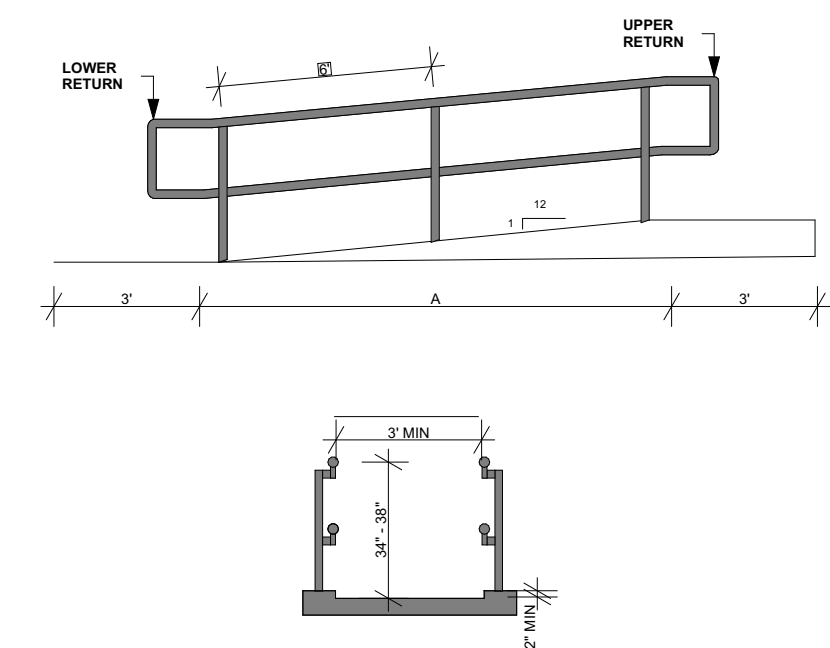

\* #18 ADA RAMP  
TO PLAY AREA  
A. LENGTH T.B.D.

**DETAIL #13**



BISON ULTIMATE™  
ADJUSTABLE STEEL  
SYSTEM

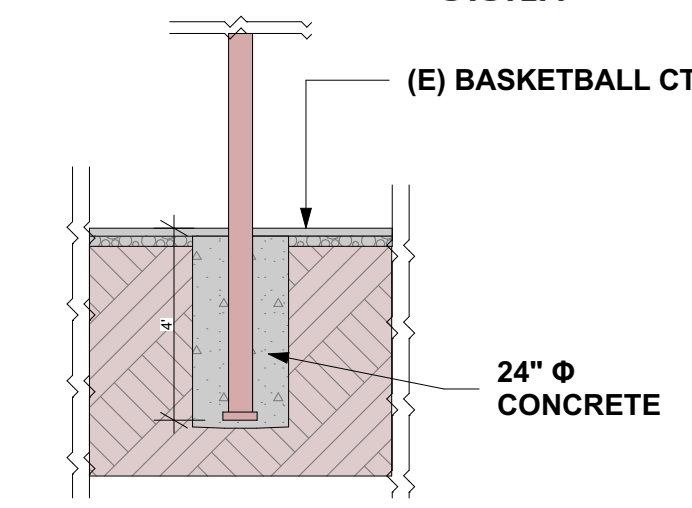

BASKETBALL POST

**DETAIL #16**

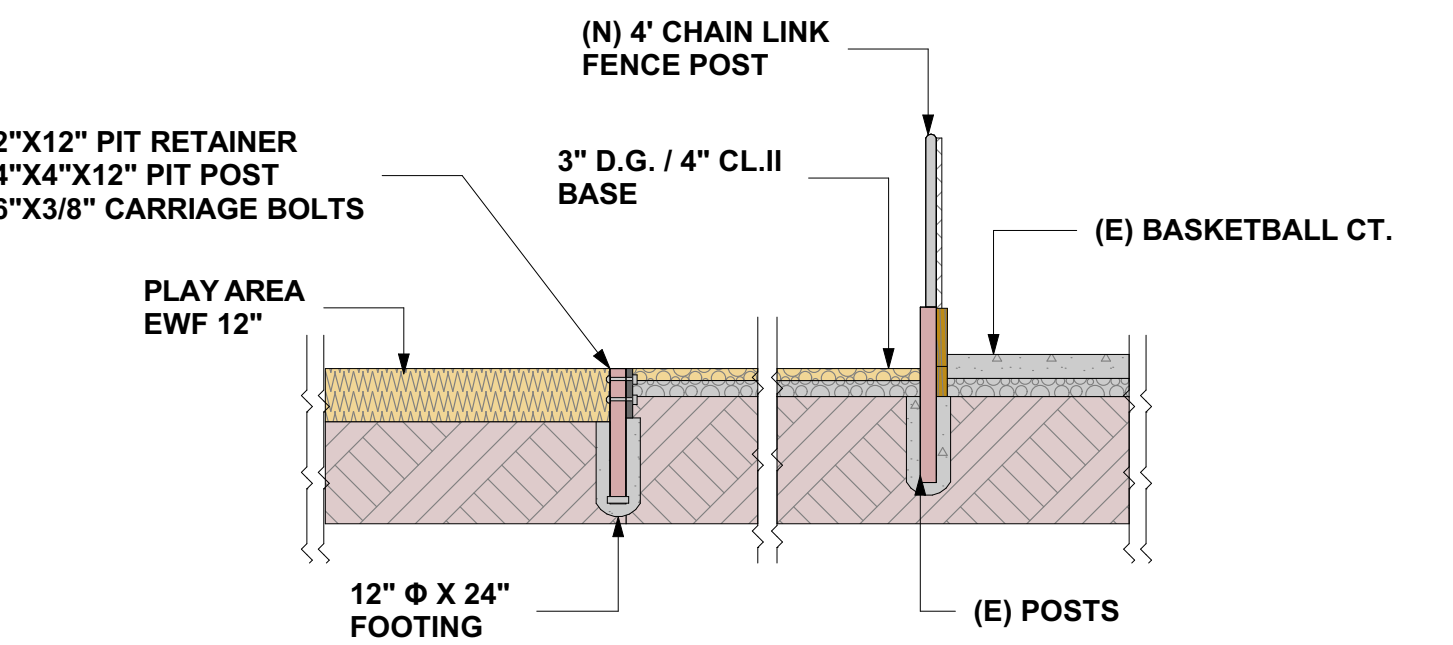

PICNIC AREA  
BID ITEM #16

**DETAIL #18**

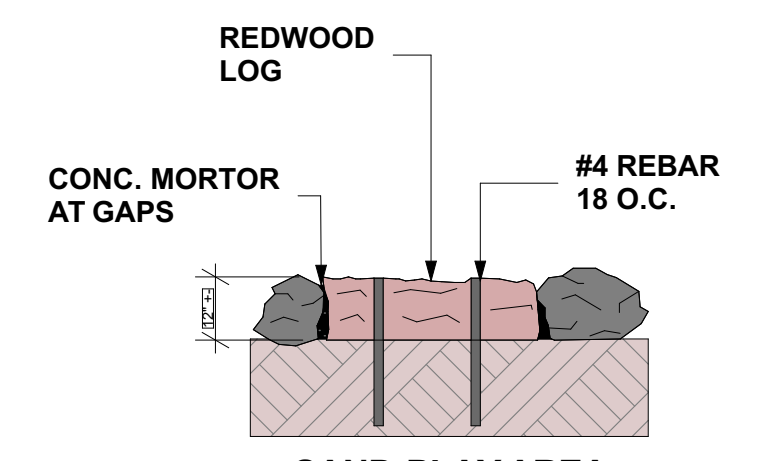

SAND PLAY AREA  
BID ITEM #18

**PLAY AREA DEVELOPMENT**

6. Refurbish Fence Along Access Road
7. Relocate Shade Umbrella & Tot Swing
8. (N) Chain Link Fence 4' HT.
9. Relocate/ Repair 2-5 Play structure
10. Repair 5-12 Play Structure
11. Top Off EWF Wood Chips 25 CY
12. Arch Basket Swing and Solo Spinner

**ATHLETIC COURTS**

13. Furnish/Install Basketball Standard
14. Repair Cracks & Slurry Seal Courts
15. Restripe Courts/White Paint

**PARK IMPROVEMENTS**

16. Furnish/Install Picnic Area
17. Furnish/Install Jug filler Fountain
18. Provide/Install Sand Play Area
19. Furnish/Install Entry Ramp & Railings
20. Furnish/Install Curved Trex Benches (2)

**ADD ALTERNATE ITEMS**

- ADD ALT 1. Furnish/Install STD Drinking Fountain in play area
- ADD ALT 2. Furnish/Install Rock Craft Ledge
- ADD ALT 3. Furnish/Install Gametime Vista Tree top 2
- ADD ALT 4. Furnish/Install Playcraft play Panels
- ADD ALT 5. Relocate Ball back Board
- ADD ALT 6. Re Grade sports court to mitigate slope
- ADD ALT 7. Color coat and Restripe Courts

**DETAIL #8**

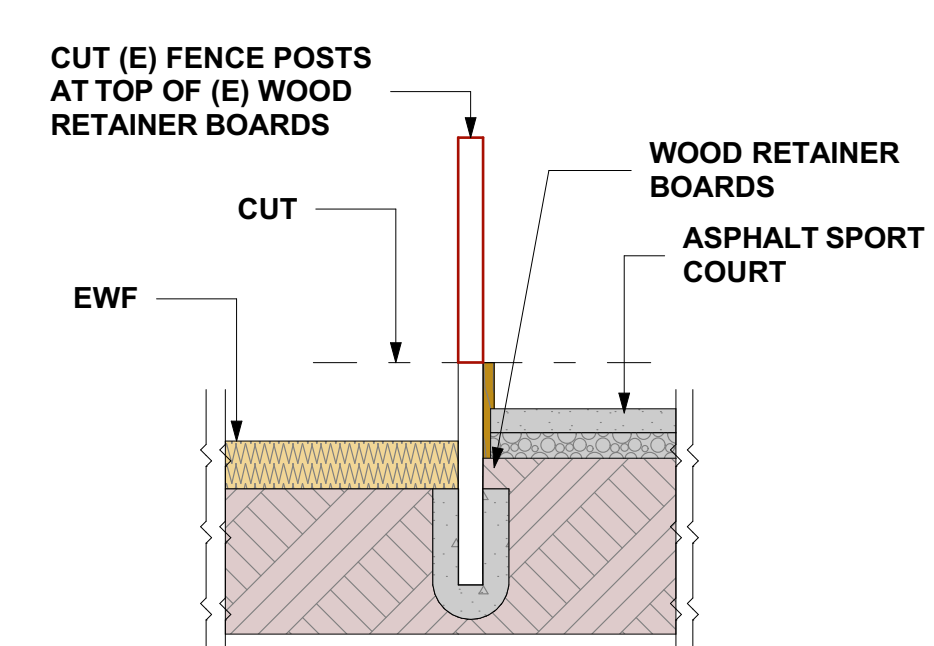
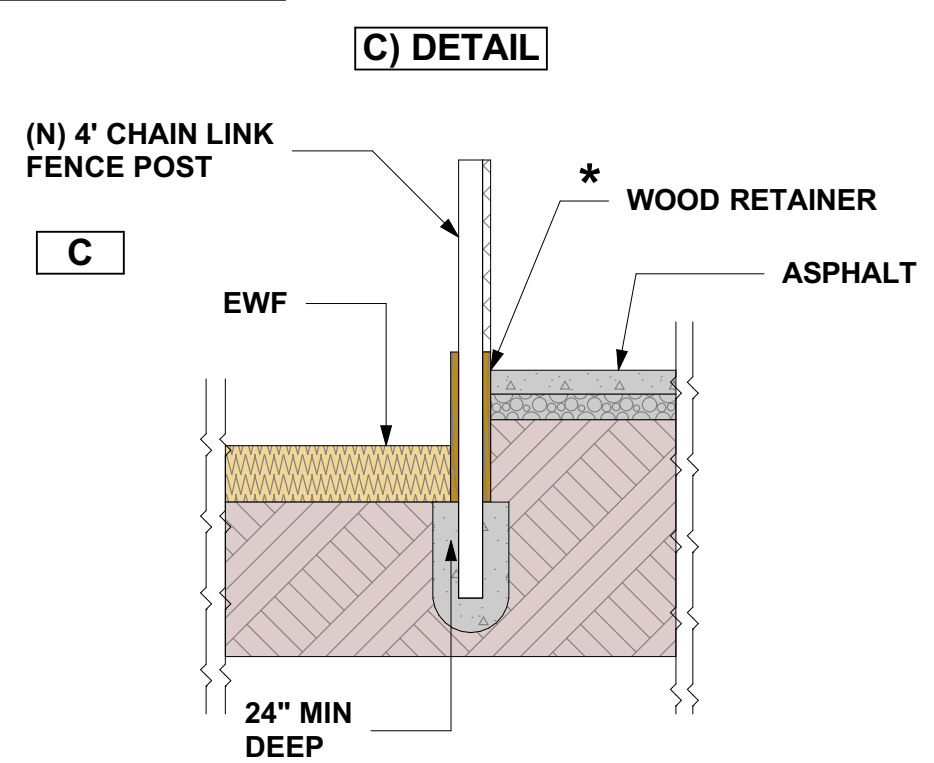

\* INSTAL NEW CLF POST  
BETWEEN (E) WOOD POSTS

**HIGHLANDS PARK  
CHAIN LINK FENCE**



ACTUAL PHOTO

**BID ITEM - ADD ALT #1**



DRINKING FOUNTAIN  
ELKAY MODEL NUMBER :  
LK4420EVG  
BID ITEM - ADD ALT #1

**BID ITEM #17**



JUG FILLER  
MODEL NUMBER : LK4420EVG  
BID ITEM #17

**DETAILS**



**Highlands Recreation Center, Lexington Avenue  
SAN MATEO , CA.**

SCALE: 1/4" = 1'-0"  
February 28 2022



KEY	Dimension "A"
Seat Type	
Belt	N/A
Flat	N/A
Full Bucket	8'-6" (2,59 m)
Half Bucket	12'-6" (3,81 m)
Molded Bucket	N/A
Molded Bucket/Harness	N/A
Infant Full Bucket	8'-6" (2,59 m)



**SAFETY NOTE**  
 Choose a protective surfacing material that has a Critical Height Value of at least the height of the Highest Accessible Part/Fall Height of the adjacent equipment. (Ref. ASTM F1487.)

18502100

**DETAIL SWING BEAM ATTACHMENT**

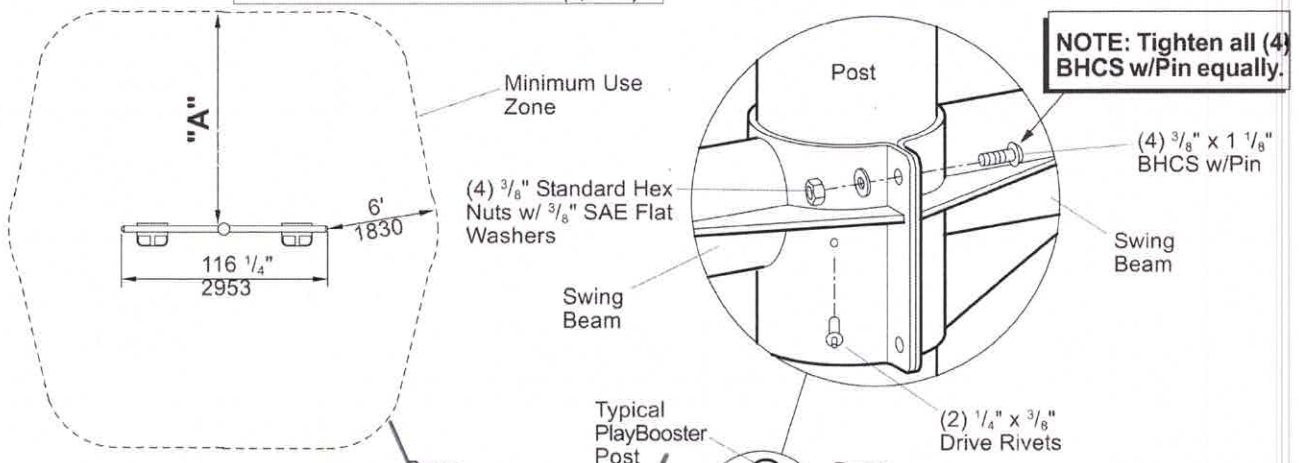

**DETAIL DOUBLE CLEVIS ATTACHMENT**

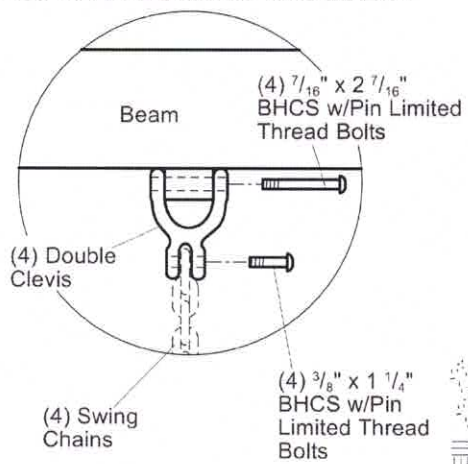

**NOTE:**  
 This Swing is designed for users up to 5 years of age.

**NOTE:** Model number is for swing frame only, order swing seats with chains separately.

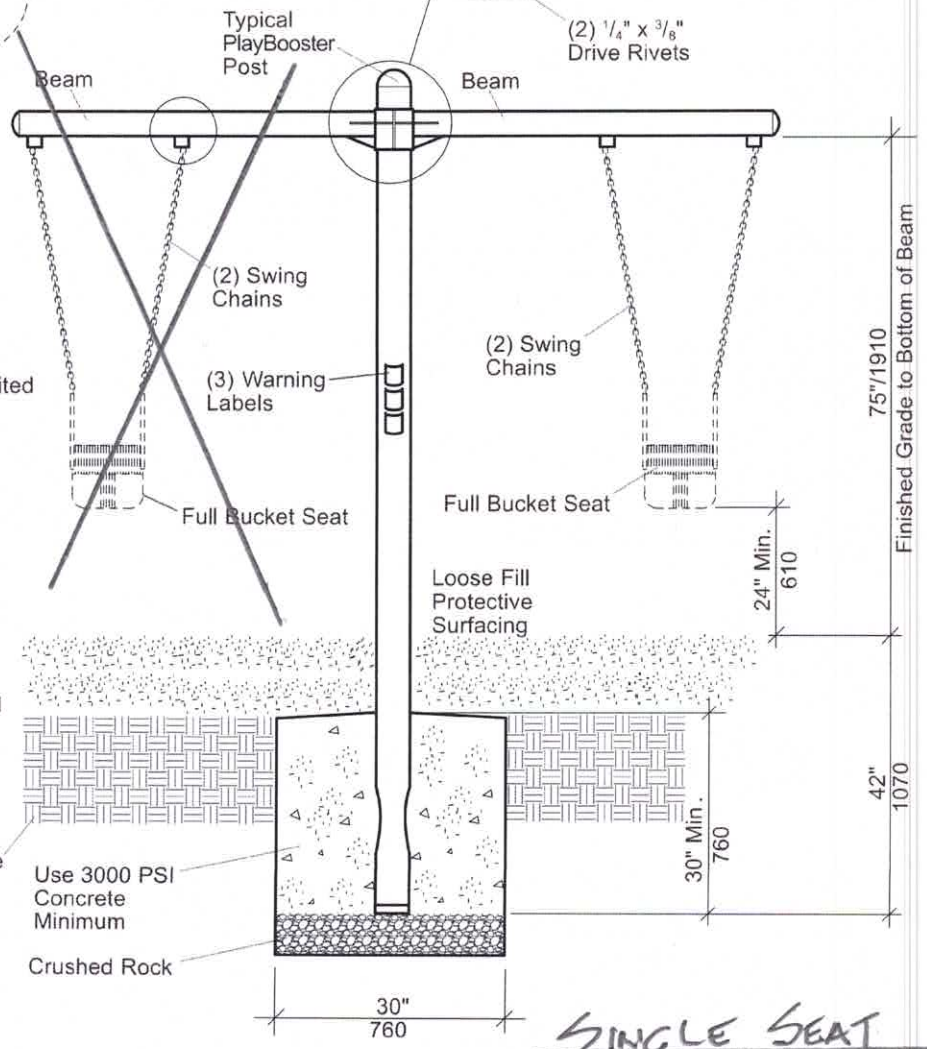

**Swings 177336 Toddler Swing Frame**





# Swings 177336 Toddler Swing Frame

## Parts List

Part#	Description	Qty.
135548-00	Swing Beam, Specify Color .....	2
116653-00	Steel 124" (DB) Post, Specify Color .....	1
<b>185014-00</b>	<b>Beam Hardware Package .....</b>	<b>1</b>
100198-00	1/8" x 1 1/8" BHCS w/Pin, SST .....	4
100327-00	3/8" Standard Hex Nut, SST .....	4
100365-00	3/8" SAE Flat Washer, SST .....	4
100611-00	1/4" x 3/8" Drive Rivet, AL/SST .....	2
182213-00	Hot Surface Warning Label .....	1
182212-00	Entanglement Warning Label .....	1
115176-00	Hard Surface Warning Label .....	1
<b>132634-00</b>	<b>Double Clevis Hardware Package .....</b>	<b>2</b>
127068-00	7/16" x 2 7/16" BHCS w/Pin Ltd. Thread Bolt, SST., 4	4
100292-00	3/8" x 1 1/4" BHCS w/Pin Ltd. Thread Bolt, SST ....	4
138917-00	Double Clevis .....	4

## Specifications

**Post:** See PlayBooster® (PB) General Specifications.

**Swing Beam:** Weldment comprised of 3.500" O.D. RS-20 (.120" - .130") galvanized steel tubing, 6" wide zinc plated steel clamp, 3.500" pipe cap, and 1 1/4" housings with bronze bushings. Finish: ProShield®, color specified.

**Fasteners:** Primary fasteners shall be socketed and pinned tamperproof in design, stainless steel (SST) per ASTM F 879 unless otherwise indicated (see specific product installation/specifications).

**Installation Time:** Approx. 4 man hours

**Concrete Req.:** Approx. 12.7 cu. ft.

**Area Req.:** 17' x 21' 9" (5,18 m x 6,63 m)

**Weight:** 136 lbs.

## Installation Instructions

- 1) Dig footing spaced as shown.
- 2) Attach swing beams to post using 3/8" x 1 1/8" BHCS w/pin and 3/8" standard hex nuts with 3/8" SAE flat washers. Refer to the Swing Beam Attachment Detail. **NOTE:** Tighten all (4) BHCS w/Pin equally.
- 3) Set post with swing beams in footing hole and with post plumb, temporarily prop in position. **NOTE:** Bottom of beam should be 75" above finished grade.
- 4) Pour concrete footing and let cure for 7 days before proceeding. **NOTE:** Use 3000 PSI concrete minimum.
- 5) Attach double clevises to beams using 7/16" x 2 7/16" BHCS w/pin limited thread bolts, and attach swing chains to double clevises using 3/8" x 1 1/4" BHCS w/pin limited thread bolts. Refer to the Double Clevis Attachment Detail.
- 6) Install Swing Bucket Seat per the installation sheet.
- 7) Drill through hole in steel half clamps and into post with a 1/4" or "F" (only) drill bit. Install 1/4" x 3/8" drive rivets. Refer to the Swing Beam Attachment Detail.
- 8) Apply Warning Labels, as shown.
- 9) Install protective surfacing before users are allowed to play on the structure.

HIGHLANDS  
RECREATION CENTER  
SAN MATEO, CA.

ROSS RECREATION  
PRESALE #: 148988-REV1

SCALE 1/4" = 12"

THIS PLAY AREA & EQUIPMENT IS  
DESIGNED FOR AGES 2-5 YEARS

THE EQUIPMENT ON THIS PLAN  
IS SHOWN & WANTED TO BE IN  
CONFORMANCE WITH THE  
FOR TESTING & MATERIALS (ASTM) FIRST  
STANDARDS FOR PUBLIC SAFETY.

IF IN THE MANUFACTURERS OPINION THAT  
ACCESSIBILITY REQUIREMENTS OF THE A.D.A.  
(AMENDMENTS WITH REQUIREMENTS ACT).

NOTE: ALL ABOVE DIMENSIONS ARE  
BEFORE FINISHES. PROVIDE  
INDIVIDUAL INSULATION COMPONENT  
INSTRUCTIONS FOR DETAILS.

BEFORE OF THE RECESS FIT OF U.S.L.  
CONCRETE FINISHES. PROVIDE  
SLAB REINFORCING BARS & CHAIR BARS BEFORE  
CONCRETE FOOTINGS ARE POURED

CONCRETE FOOTINGS ARE REQUIRED ON  
ALL IN-GROUND COMPONENTS.

CHOOSE A PROTECTIVE SURFACING MATERIAL  
FOR THE PLAY AREA. PROVIDE  
AT LEAST THE HEIGHT OF THE HIGHEST  
ACCESSIBLE PART/FULL HEIGHT OF THE  
ADJACENT EQUIPMENT. (SEE CONSUMER  
GUIDELINES SECTION 10 SURFACING)

PLAYSHAPER

ORDER #: T31137A

PART A

2-6-02 ENGINEERED BY: MJF

LANDSCAPE  
STRUCTURES INC

Anything else is cutting corners.

601 7th STREET SOUTH - P.O. BOX 198  
DELANO, MINNESOTA 55328  
PH: 1-800-338-0035 FAX: 1-763-972-8991

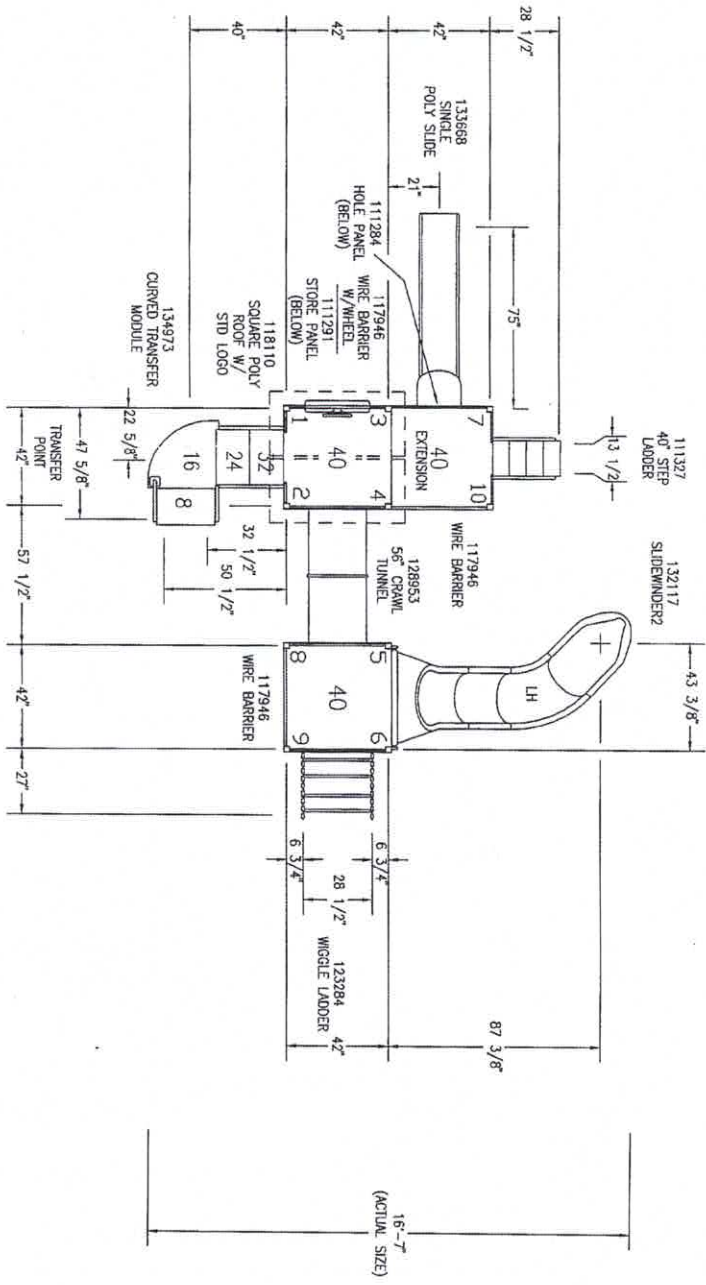

POST/ARCH LENGTHS

1-4	=	129"	ROOF POST
5-7	=	114"	DECK POST
8-10	=	106"	DECK POST

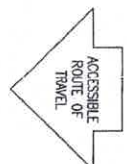

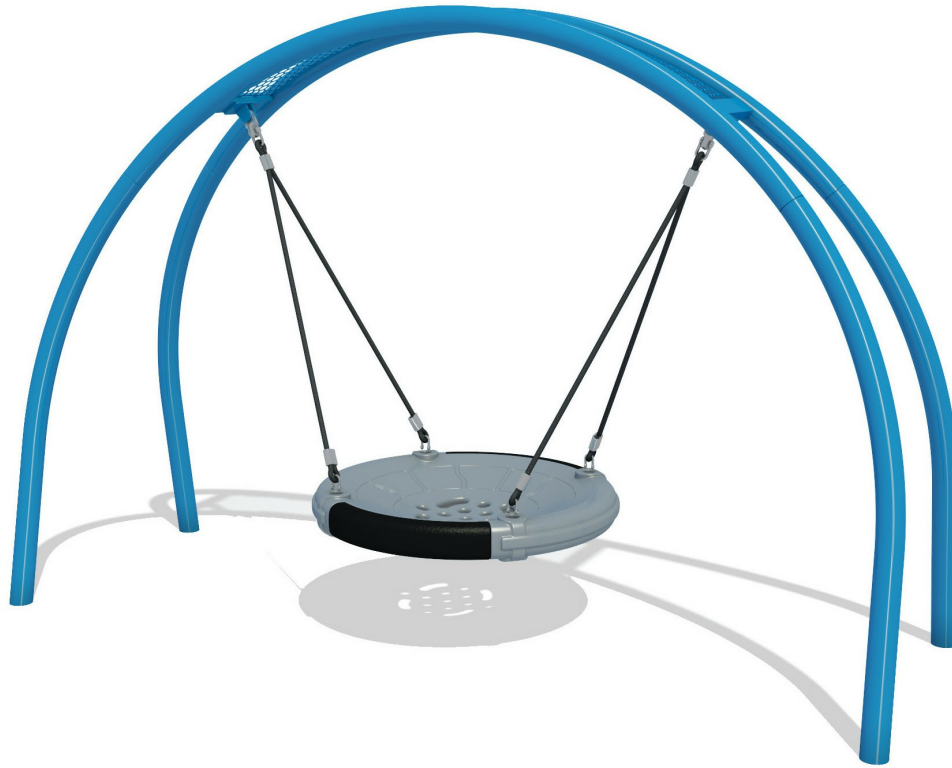

The Arch Swing is a fun and accessible way to add swinging motion to your playground. The wide seating area accommodates up to five children. Children with Sensory Processing Disorder, or similar sensory issues, can lay across the center section and enjoy the calming to-and-fro motion. Children can also sit around the perimeter of the seat and enjoy swinging together.

## Features and Benefits:

- Arch uprights are constructed of durable 3.5" galvanized steel
- Metal insert at the top of the arch provides shade from direct sunlight
- Transfer point for wheelchair or other mobility device
- Provides calming to-and-fro motion for children with sensory issues
- Offers a fun, collaborative play activity for...

Model: 5056  
Use Zone: 23'-2" X 24'-9"  
Fall Height: 8'  
Age Group: 2 to 5 Years  
Age Group: 5 to 12 Years

Limited Lifetime Warranty on uprights, hardware and connections. Visit [gametime.com/warranty](https://www.gametime.com/warranty) for full warranty information



Designing award-winning playgrounds since 1929.



Certified Installer Network - GameTime trained for GameTime playgrounds.



Complies with ASTM standards before it leaves the factory.



Just keep spinning! This solo spinner offers a low footprint design, built to perfectly complement a small space or to add a spinning element to your playground.

### Features and Benefits:

- Solo Spinner's compact size is perfect for a small space
- Great addition to existing playgrounds
- Kids can enjoy the freeing, spinning joy of motion

Model: 6246  
Use Zone: 13'-4" X 13'-4"  
Fall Height: 4'  
Age Group: 2 to 5 Years  
Age Group: 5 to 12 Years

Limited Lifetime Warranty on uprights, hardware and connections. Visit [gametime.com/warranty](http://gametime.com/warranty) for full warranty information



Designing award-winning playgrounds since 1929.



Certified Installer Network - GameTime trained for GameTime playgrounds.



Complies with ASTM standards before it leaves the factory.

HANGING CANTILEVER SHADE

24' x 14' x 8'

MODEL #:  
HC241408IG (With Glide Elbows)

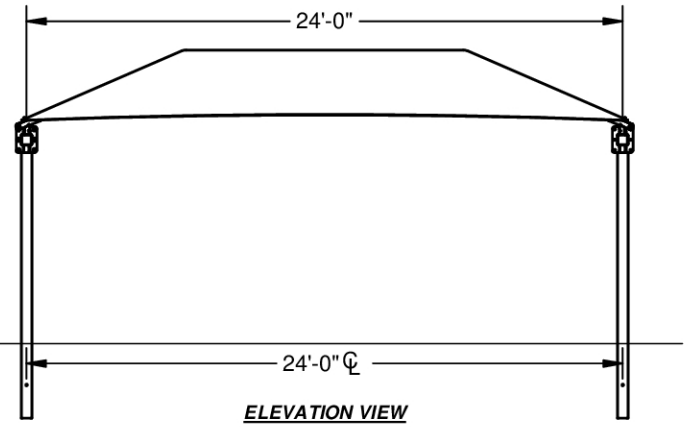
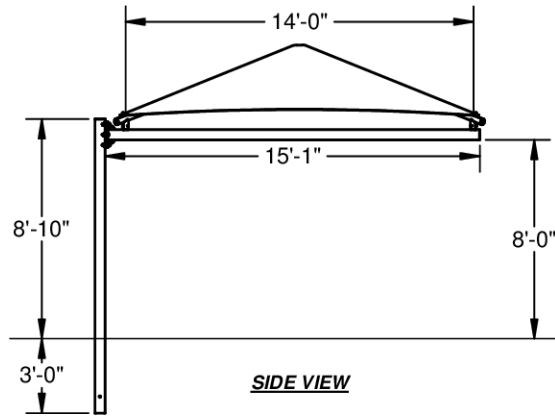

REF.#	PART DESCRIPTION	QTY.
1	5" Sq. Surface Mount Column	2
2	5" Sq. Beam With Caps	2
3	Ø2 7/8" Angled Elbow	4
4	Ø2 7/8" Hip Rafter w/ Swaged End	4
5	Ø2 7/8" Ridge Pole w/ Swaged Ends	1
6	Ø2 7/8" Rectangle "Y" Connection	2
7	Fabric Cover With Cable Insert	1
8	Frame Hardware Kit	1

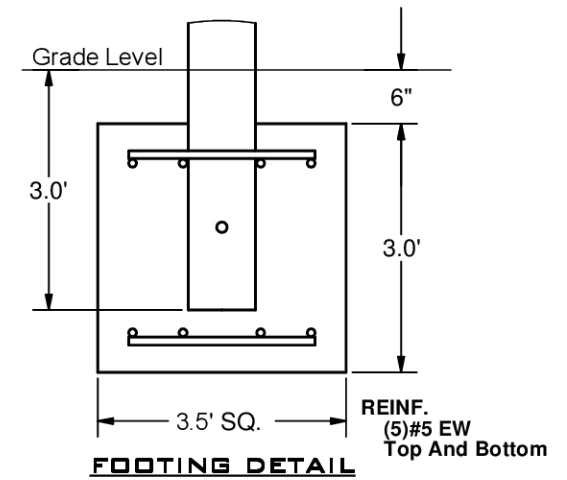
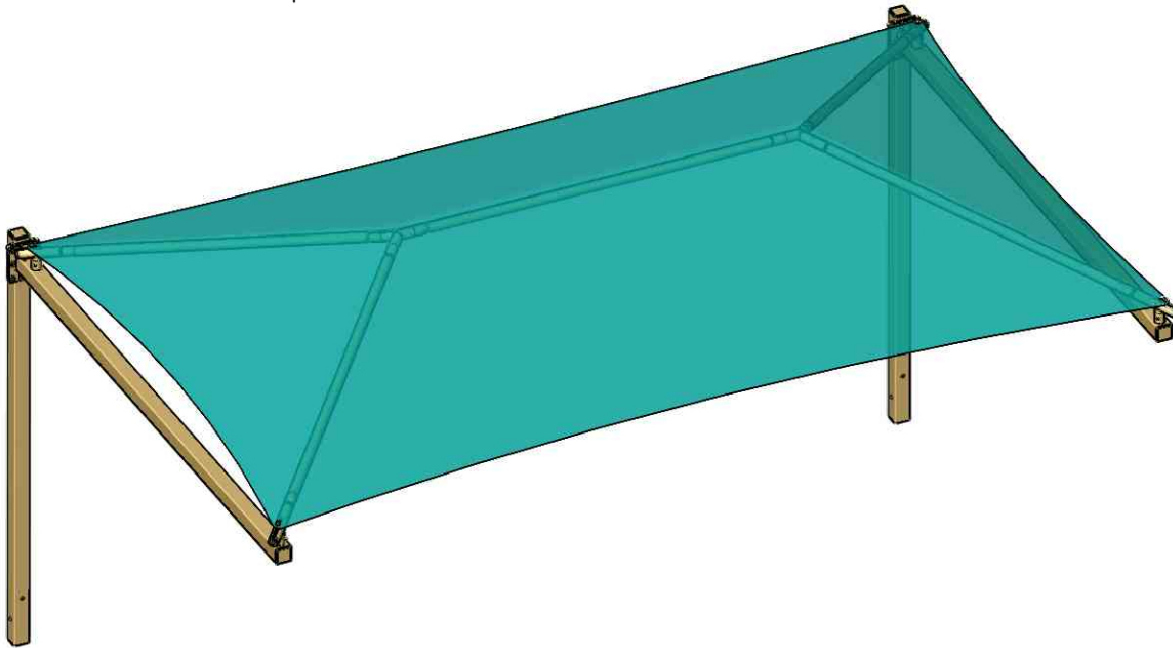

\*Footing design based on 1500 PSF soil bearing pressure.













## **ELECTRICAL REQUIREMENTS**

1. Provide work that complies with the 2019 editions of the California Building Code and the California Electrical Code. Provide materials that are UL-listed.
2. Provide equipment and materials submittals for the following items only:
  - 2.1. Sports luminaires, poles, and accessories
  - 2.2. Controls cabinet
  - 2.3. Relays, manual motor starter, timeswitch, photocell, and pushbuttons.
3. Materials:
  - 3.1. Provide PVC-40 conduit underground and galvanized rigid steel conduit with threaded fittings in above-grade locations.
  - 3.2. Provide 600V copper THHN/THWN conductors. #12 AWG may be solid or stranded.
  - 3.3. Provide NEMA 4X stainless steel controls cabinet with hinged cover by Hoffman or approved equal. Provide with a hasp for padlocking.
4. Controls: Set the basketball lighting timeswitch N.O. contact to close at 4:00 PM and open at 10:00 PM. Verify the schedule with the district's general manager. The lights are enabled to run after the timeswitch and the photocell normally-open contacts have closed. Set the timing relays for instantaneous close and 60-minute delay open. Label the pushbuttons to indicate which court is controlled.
5. Trenching: Sawcut existing paved surfaces which must be trenched, backfill with 90% compaction, and patch the cut surface to match the surrounding undisturbed area.

\*\*\* End of Electrical Requirements \*\*\*



WWW.ROCKCRAFT.NET

# LEDGE

## LDG-784



The Ledge is specially designed for preschool and school age children. Ages 2-5

The boulder features easily accessible routes and an overhang that encourages children to make their way to the top.

Height can be varied from 3'6" to 5' depending on the installation

Base dimensions: 4' x 4'

Approximate overall size: 4' Long x 4' Wide x 6' High

The Ledge requires a minimum 6' fall zone. Total minimum use zone required 18' x 18'



### 15 Year Limited Warranty

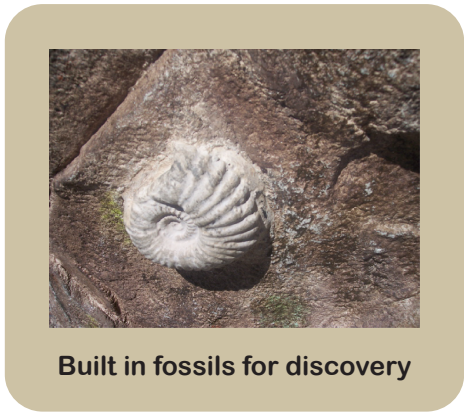

Built in fossils for discovery

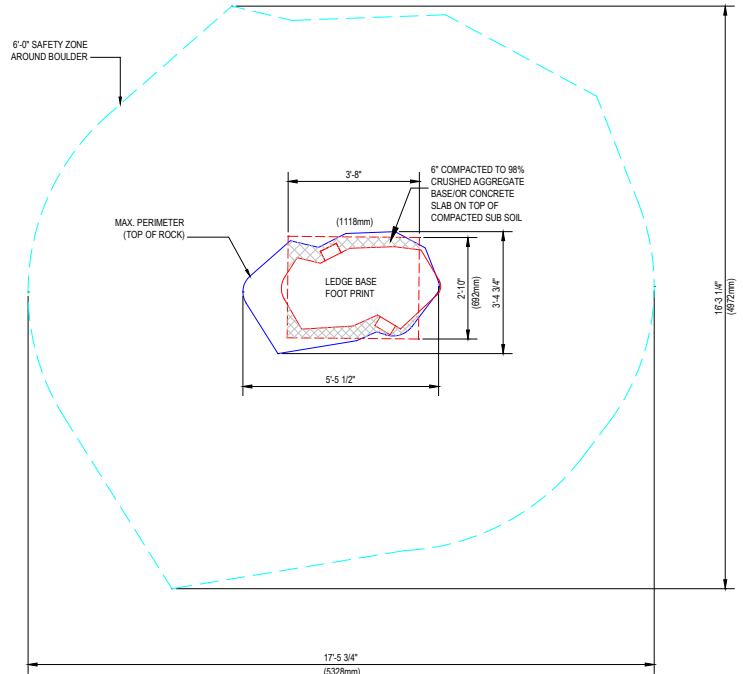

NOTES:  
1. INSTALLATION TO BE COMPLETED IN ACCORDANCE WITH MANUFACTURER'S SPECIFICATIONS.  
2. DO NOT SCALE DRAWINGS.  
3. DOUBLE CHECK DIMENSIONS WITH MANUFACTURER. ALL MEASUREMENTS ARE APPROXIMATE DUE TO THE NATURE OF THE PRODUCT.



To verify product certification, visit [www.ipema.org](http://www.ipema.org)



To verify product certification, visit [www.ipema.org](http://www.ipema.org)



WWW.ROCKCRAFT.NET

## LEDGE BOULDER (LDG-784) DESCRIPTION AND SPECIFICATIONS

### STRUCTURE:

The Ledge Boulder is handcrafted from our special concrete formula. Constructed from specially mixed 65 mpa or 9500 psi concrete for increased strength and elasticity as well as pumice for reducing weight. The concrete is additionally reinforced by rebar and two integral layers of steel mesh. A lifting eye is located at the centre balance point of each piece for moving and shipping.

### CLIMBING SURFACE:

Our structures are designed to have a realistic but friendly finish. After sculpting and curing, our pieces are hand finished with an abrasive stone to duplicate natural glacial polishing and weathering. As the concrete continues to cure and adjust to climate hairline cracks may occur. Hairline cracking is natural and structurally does not in any way affect the integrity and structural strength of the piece.

### HOLDS:

The Ledge's holds include *jugs, crimps, pinches, under-clings, slopers, slide-pulls, ledges, and flakes* of various sizes and degrees of difficulty that provide challenges and fun for ages ranging from 3 to adult. Our holds are all self-draining to eliminate water collection and freeze/ thaw cracking.

### PAINT:

The Ledge is hand painted and clear coated for protection from the elements. Custom sculpting and painting can be provided to match our product to the look of your local limestone, sandstone or quartzite. The clear coat sealant also allows graffiti to be removed easily, but our experience has been little or no tagging actually takes place.



The Ledge requires a 6 ft. fall zone.

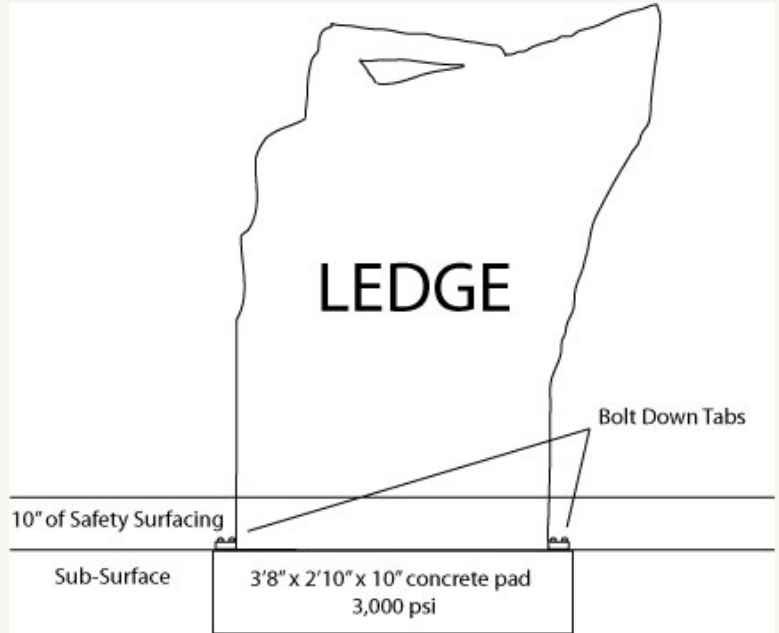

### INSTALLATION INSTRUCTIONS

The Ledge is manufactured and shipped as one piece. Excavate to allow for a rebar reinforced concrete pad of 3'8" x 2'10" x 10", with the top of the pad to be level with sub-surface grade. The pad requires a single layer of 5/8" diameter rebar spaced 18" apart, 1" from the outside edge. This must be done 2-3 days before the boulder arrives. If necessary, for a soft-subsurface, compact 3/4" down A-base underneath the concrete pad.

Once the pad has set, for permanent installation apply non-shrinking grout to the top of the pad. Lift the boulder using the provided nylon sling through the lifting eye with a skidsteer, crane or boom truck and place onto the freshly grouted concrete pad.

Bolt down the boulder where the bolt down tabs are shown. Use a hammer drill with a 1/2" bit and the supplied hardware.

### SAFETY SURFACE

The Ledge is typically installed with 10 inches of wood fiber as a safety surface. Alternatively, sand, pea gravel, poured in place rubber or 3" rubber tile surface are other options for the safety surface.

**Dimensions:** approximately  
6' high  
6.5' diameter at the top with 5' diameter at base

**Weight:** approximately  
2300 lbs.

Reb Mar, 2011



VistaTree nets are a combination net spinner and climber. It's two times the fun in a single freestanding play activity! Constructed with our durable WeaveTech® cabling system, VistaRope products are up to 4x stronger than competing rope products. Each rope contains the industry's highest steel content for maximum durability and is coated with our ComfortGrip® synthetic...

### Features and Benefits:

- Fun climbing and spinning activity for multiple users
- Provides sensory and developmental benefits for ages 5 to 12
- Constructed with our WeaveTech cabling system for maximum strength and durability

Model: 5959SP  
 Use Zone: 22'-10" X 22'-10"  
 Fall Height: 7'  
 Age Group: 5 to 12 Years  
 Number of Children: 25-30

Limited Lifetime Warranty on uprights, hardware and connections. Visit [gametime.com/warranty](http://gametime.com/warranty) for full warranty information



Designing award-winning playgrounds since 1929.



Certified Installer Network - GameTime trained for GameTime playgrounds.



Complies with ASTM standards before it leaves the factory.